

LA2Xi

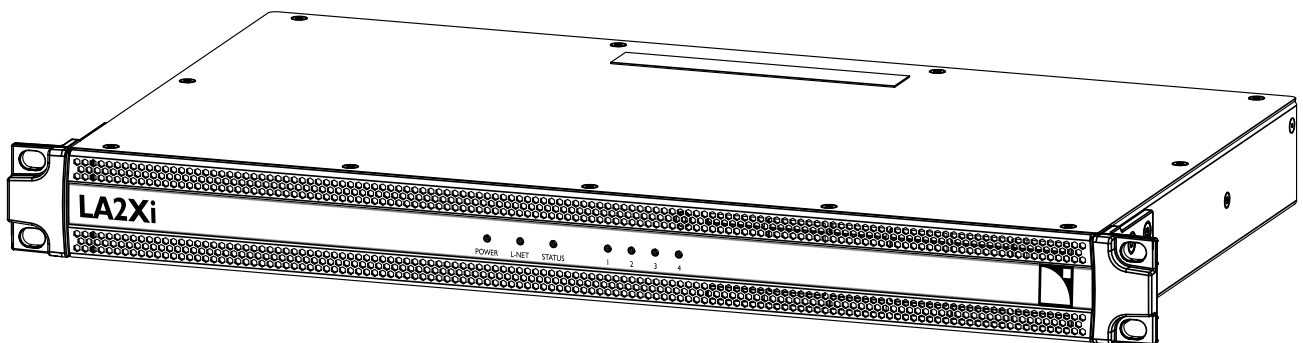

owner's manual (EN)



Document reference: LA2Xi owner's manual (EN) version 3.6

Distribution date: February 6, 2024

© 2024 L-Acoustics. All rights reserved.

No part of this publication may be reproduced or transmitted in any form or by any means without the express written consent of the publisher.

Contents











Safety.....	6
Important safety instructions.....	6
Introduction.....	9
LA2Xi amplified controller.....	9
How to use this manual.....	9
Revision history.....	10
System components.....	11
Technical description.....	12
Main features.....	12
Internal components.....	12
Front and rear panels.....	12
Signal processing and amplification.....	12
Signal inputs.....	12
DSP architecture.....	14
Power supply and amplifier section.....	15
Speaker outputs.....	15
Speaker protection.....	16
Monitoring and control.....	16
User interface.....	16
L-NET remote control network.....	16
Inspection and preventive maintenance.....	18
How to do preventive maintenance.....	18
CHK - External structure.....	18
CHK - Cleanness.....	19
CHK - Normal start-up sequence.....	19
CHK - Network functionalities and firmware.....	19
Installation.....	20
Mounting.....	20
Ventilation.....	20
General Purpose I/O (GPIO).....	21
Connecting to AC mains.....	22
Electrical specifications.....	22
Planning the power of the electrical generator.....	22
Power cord.....	23
Plugging the amplified controller.....	23

Power consumption.....	24
Heat power calculation.....	24
24 V DC Input.....	25
Audio and network cabling.....	26
Connection panels.....	26
Analog audio.....	28
Digital audio.....	29
L-NET/AVB.....	30
Speaker.....	31
Connector references.....	32
Operation.....	33
Powering on/off.....	33
Interpreting the front panel LEDs.....	33
L-NET.....	33
STATUS.....	33
Meters.....	34
Other operations.....	35
Corrective maintenance.....	36
Introduction.....	36
Equipment and tools.....	36
Screw repair kit.....	36
Troubleshooting and diagnosis.....	38
LED issues.....	38
L-NET network issues.....	39
Sound issues.....	40
Error messages.....	42
Exploded view.....	44
External modules.....	44
Disassembly and Reassembly procedures.....	45
D/R - Lexan and grill.....	45
D/R - Front brackets.....	47
Specifications.....	48
General.....	48
Input signal distribution.....	50
Latency.....	51
Milan-AVB.....	51
Automatic fallback option.....	52
Remote control and monitoring.....	52
Physical data.....	53

Appendix A - Optional LA2Xi I/O-CON accessory.....	54
LA2Xi I/O-CON panel.....	55
Connection panels.....	57
Speaker connectors.....	57
Analog/Digital output connectors.....	58
Speaker.....	59
Specifications.....	60
LA2Xi I/O-CON.....	60
Appendix B - Glossary.....	61
Appendix C - Approvals.....	62

Safety

Important safety instructions

- 
Inspect the product before operation.
 If any sign of defect or damage is detected, immediately withdraw the product from use for maintenance.
- 
Perform preventive maintenance at least once a year.
 Refer to the preventive maintenance section for a list of actions and their periodicity.
 Insufficient upkeep of the product can void the warranty.
- 
Verify the electrical conformity and compatibility of the mains supply.
 Only connect the product to an AC power outlet rated 100-240 V, 50-60 Hz, with the following current values:
 100 V (Japan): 20 A
 120 V (North America): 15 A
 220-240 V (EU): 10 A
 WARNING: The product is of Class 1 construction and shall be connected to a mains socket outlet with a Protective Earth connection.
- 
When the product is used in a three-phase circuit, verify the electrical conformity and compatibility of the three-phase circuit.
 Verify that the three phases work, and balance the loads between the three phases.
 Verify that the neutral and earth work.
 Never try to emulate a 230 V circuit connecting an apparatus to two live wires of a 120 V three-phase circuit.
 Never try to emulate a 200 V circuit connecting an apparatus to two live wires of a 100 V three-phase circuit.
- 
Always interconnect a circuit breaker between the product and the mains supply.
 Use these references, or equipment with equivalent characteristics:
 100 V (Japan): 20 A Terasaki S125-NF 1P
 120 V (North America): 15 A Square D QO
 220-240 V (EU): 10 A Type C
- 
Electrical generator
 You must power on the generator before powering on the product.
- 
Terminals marked with the lightning flash symbol are HAZARDOUS LIVE.
 The external wiring connected to these **terminals** requires installation by an **instructed person** or the use of ready-made leads or cords.
 Never attempt to touch any exposed speaker wiring while the product is operating: first disconnect the connector from the product.
 Mute all output channels before connecting a speaker to an amplified controller.
 Do not connect a speaker output in parallel or series with any output of another amplified controller.
 Do not connect the speaker outputs to any other voltage source, such as a battery, power mains, or power supply, regardless of whether the amplified controller is turned on or off.
- 
- 
Never incorporate equipment or accessories not approved by L-Acoustics.
- 
Read all the related PRODUCT INFORMATION documents shipped with the products before exploiting the system.
- 
Intended use
 This system is intended for use by trained personnel for professional applications.

 **As part of a continuous evolution of techniques and standards, L-Acoustics reserves the right to change the specifications of its products and the content of its documents without prior notice.**

Check www.l-acoustics.com on a regular basis to download the latest document and software updates.

 **Beware of sound levels.**

Do not stay within close proximity of loudspeakers in operation.

Loudspeaker systems are capable of producing very high sound pressure levels (SPL) which can instantaneously lead to permanent hearing damage to performers, production crew and audience members. Hearing damage can also occur at moderate level with prolonged exposure to sound.

Check the applicable laws and regulations relating to maximum sound levels and exposure times.

 **Beware of over power risks.**

Only use compatible loudspeakers with appropriate presets to avoid damage to the loudspeakers.

 **Do not use the product outside its operating temperature range.**

The product operates at a room temperature between -5 °C / 23 °F and 50 °C / 122 °F.

Do not expose the product to direct sun.

 **Do not expose the product to extreme conditions.**

Do not expose the product to moisture (rain, mist, sea spray, steam, humidity, condensation...) or excessive heat (direct sun, radiator...) for a long period of time.

For more information, refer to the **Products weather protection** document, available on the website.

 **Use the product in a conformed electro-magnetic environment.**

The product can be used in the following environment: residential (class B).

Avoid radio interference.

This product has been tested and complies with the regulations of the EMC directive (Electro Magnetic Compatibility). These regulations are designed to provide reasonable protection against harmful interference from electrical equipment, but it cannot be guaranteed that interference will never occur.

 **Product disconnection**

To completely disconnect this product from the mains, disconnect the power supply cord plug from the mains socket outlet.

 **Power supply cord and socket accessibility**

The main plug of the power supply cord shall remain easily accessible.

The mains socket outlet shall be easily accessible.

 **Read the maintenance section of this document before servicing the product.**

 **Contact L-Acoustics for advanced maintenance.**

Any unauthorized maintenance operation will void the product warranty.

Before sending a product to L-Acoustics for maintenance, save all user presets to files using LA Network Manager.

 **Shipping**

Use the original packaging for shipping the product, unless it is mounted in a rack with the front fixed to the rack, as described in this manual.

Symbols on the product



Explanation of graphical symbols



The lightning flash with arrowhead symbol within an equilateral triangle is intended to alert the user to the presence of uninsulated "dangerous voltage" within the product's enclosure that may be of sufficient magnitude to constitute a risk of electric shock to persons.



The exclamation point within an equilateral triangle is intended to alert the user to the presence of important operating and maintenance instructions in the literature accompanying the product.



Do not open unless authorized. This symbol indicates the presence of electrical shock hazards. It also indicates that no maintenance performed by the end user requires access to internal components.



This marking indicates that this product should not be disposed of with other household waste throughout the EU. To prevent possible harm to the environment or human health from uncontrolled waste disposal, recycle it responsibly to promote the sustainable reuse of material resources. To return your used device, please use the return and collection systems or contact the retailer where the product was purchased. They can take this product for environmentally safe recycling.

Introduction

LA2Xi amplified controller



LA2Xi is a four-channel amplified controller dedicated to permanent installations. Designed to match the power of small format loudspeakers, LA2Xi can also be used to support larger loudspeakers at lower SPL capability (4 x 4 single-ended mode) or at full SPL capability (4 x 3, 4 x 2 or 4 x 1 bridge mode).

The streamlined and elegant 1U front panel hides a powerful DSP engine with features for loudspeaker management, protection and monitoring as well as a comprehensive set of tools for system adjustment and calibration. In addition to analog and AES, LA2Xi integrates AVB signal inputs with Milan seamless network redundancy. Four GPIO and a 24 V DC backup power for the DSP card offer external control and improved reliability. The flexible LA2Xi is ideal for background music systems in leisure venues, distributed fills, studio monitors and private auditorium systems.

LA2Xi can be combined with the LA2Xi I/O-CON accessory which is an XLR and speakON optional connector panel. It is mounted at the back of LA2Xi and covers the terminal blocks to provide a solution for effective connections.

Refer to the [Appendix A - Optional LA2Xi I/O-CON accessory](#) (p.54) for more information.

How to use this manual

The LA2Xi owner's manual is intended for all actors involved in the system design, implementation, preventive and corrective maintenance of the LA2Xi product. It must be used as follows:

1. Read the technical description for an overview of all product elements, their features, and their compatibilities.
 - [Technical description](#) (p.12)
2. Before installing the product, perform mandatory inspections and functional checks.
 - [Inspection and preventive maintenance](#) (p.18)
3. To deploy the product, follow the step-by-step installation instructions and refer to the cabling schemes.
 - [Installation](#) (p.20)
 - [Audio and network cabling](#) (p.26)
4. To configure the settings and parameters of the product, follow the step-by-step operation instructions.
 - [Operation](#) (p.33)



The [Corrective maintenance](#) (p.36) section contains the operations authorized for the end user.

Performing another operation exposes to hazardous situations.

For advanced maintenance, contact your L-Acoustics representative.

As part of a continuous evolution of techniques and standards, L-Acoustics reserves the right to change the specifications of its products and the content of its documents without prior notice.

Check www.l-acoustics.com on a regular basis to download the latest document and software updates.

Contact information

For information on advanced corrective maintenance:

- contact your Certified Provider or your L-Acoustics representative
- for Certified Providers, contact the L-Acoustics customer service: customer.service@l-acoustics.com (EMEA/APAC), laus.service@l-acoustics.com (Americas).

Symbols

The following symbols are used in this document:

 This symbol indicates a potential risk of harm to an individual or damage to the product. It can also notify the user about instructions that must be strictly followed to ensure safe installation or operation of the product.

 This symbol indicates a potential risk of electrical injury. It can also notify the user about instructions that must be strictly followed to ensure safe installation or operation of the product.

 This symbol notifies the user about instructions that must be strictly followed to ensure proper installation or operation of the product.

 This symbol notifies the user about complementary information or optional instructions.

Revision history

version number	publication date	modification
1.0	Oct. 2020	Initial version.
1.1	Dec. 2020	Updated section on speaker cabling.
2.0	Mar. 2021	Updated contents for units with serial number from 1730003000 and on.
2.1	Aug. 2021	Updated recommendations for circuit breakers and mains supply.
2.2	Oct. 2021	Issue fixes and improvements.
2.3	Jan. 2022	<ul style="list-style-type: none"> Added DOE cables to System components (p.11). Updated Other operations (p.35). Corrected the latency value in low latency operating mode.
2.4	Mar. 2022	<ul style="list-style-type: none"> Updated recommendations for circuit breaker and mains supply for EU. Added SB10i in Maximum SPL (p.15).
2.5	Apr. 2022	Updated power consumption in Idle and Standby modes.
3.0	May 2022	Added Corrective maintenance (p.36).
3.1	Aug. 2022	Fixed an issue with the display of the Error messages (p.42).
3.2	Nov. 2022	<ul style="list-style-type: none"> Added recommendations on using multicore loudspeaker cables. Added SB6i in Maximum SPL (p.15).
3.3	Mar. 2023	<ul style="list-style-type: none"> Updated Power consumption (p.24) values. Removed appendix about AVB reservation (RSV) errors.
3.4	May 2023	<ul style="list-style-type: none"> Added Soka in Maximum SPL (p.15). Updated noise level in Specifications (p.48).
3.5	Dec. 2023	Added Appendix A - Optional LA2Xi I/O-CON accessory (p.54).
3.6	Feb. 2024	Added X6i and X8i in Maximum SPL (p.15).

System components

Powering and driving system

LA2Xi Install-specific amplified controller 4 × 640 W / 4 ohms

Cables

DOE cables Dual AVB Network cable CAT6A, etherCON (black = primary network, red = secondary network)
 Come in different sizes: DOE2 (2 m / 6.6 ft), DOE45 (45 m / 147.6 ft), and DOE100 (100 m / 328.1 ft)

Software applications

Soundvision 3D acoustical and mechanical modeling software
 LA Network Manager Software for remote control and monitoring of amplified controllers



Refer to the Soundvision help.

Refer to the LA Network Manager help.

Loudspeaker enclosures



Refer to the user documentation of the loudspeaker systems for detailed instructions about the enclosures and their connection to the amplified controllers.

System component illustrations

Cables

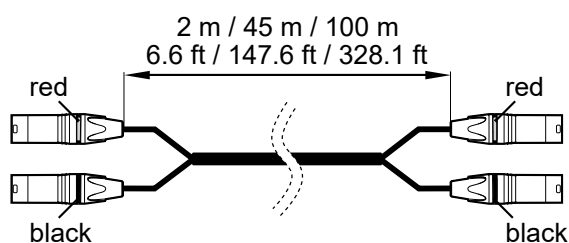

DOE cables

Software applications

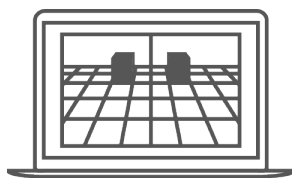

Soundvision



LA Network Manager

Technical description

Main features

Internal components

The core of the LA2Xi is a Gen. 4 dual DSP engine driving four channels of amplification from four inputs. LA2Xi features a flash memory for preset storage and management, high performance A/D-D/A converters for audio signals, a universal Switched Mode Power Supply (SMPS) with PFC (Power Factor Correction), and a dual-port Ethernet Gigabit interface.

Front and rear panels

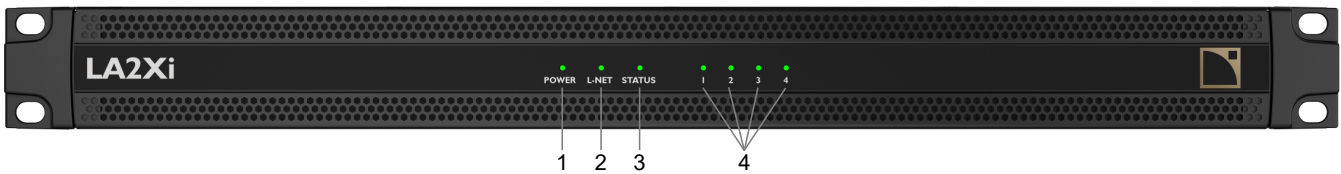

1. power LED
2. L-NET LED
3. status LED
4. signal LEDs

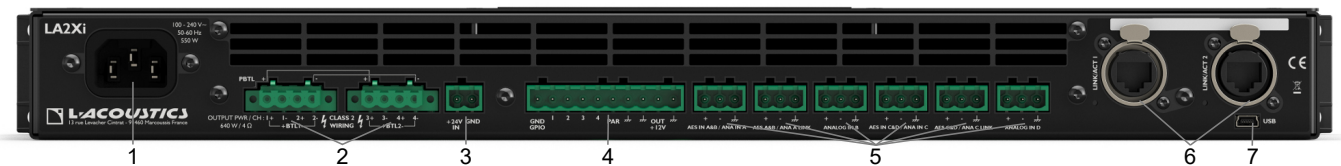

1. V-Lock compatible IEC connector
2. output female 4-point terminal blocks
3. 24 V DC male 2-point terminal block to connect a backup power supply for the DSP
4. General Purpose I/O (GPIO)
5. input/Link male 3-point terminal blocks
6. 1 Gb/s Ethernet etherCON® I/O connectors
7. mini USB for configuring IP settings - refer to the **LA Network Manager** Help

For LA2Xi I/O-CON panel, refer to [Appendix A - Optional LA2Xi I/O-CON accessory](#) (p.54).

Signal processing and amplification

Signal inputs

Milan-AVB

One AVB stream of up to eight channels may be connected to LA2Xi. LA2Xi retrieves up to four channels from this stream.

Each Ethernet port uses a high speed data transfer protocol up to 1 Gb/s and supports the IEC 61883-6 AM824 and AAF PCM32 stream formats with stream frequencies of 48 kHz or 96 kHz.

The amplified controller synchronizes its audio clock on the clock used by the talker through the incoming stream.

LA2Xi embeds an AVB bridge and may therefore be used to create an AVB network.

AES/EBU

LA2Xi can be fed with up to four AES/EBU digital audio signals (transported in pairs) using the two male 3-point terminal blocks (AES IN A&B and AES IN C&D).

The audio signals can come from a digital mixing desk or from any audio device compliant with the AES/EBU (AES3) digital audio standards.

The input signals can be transmitted to daisy-chained amplified controllers using the two male 3-point terminal blocks (AES LINK A&B and AES LINK C&D).

Each AES/EBU input port is equipped with an SRC (Sample Rate Converter) that has been selected to support a wide range of input formats (16 - 24 bits / 44.1 - 192 kHz). The SRC converts the formats to the 24 bits / 96 kHz internal format used by the amplified controller. The SRC is a high-quality hardware component (140 dB dynamic range, THD+N < -120 dBFS, strong input jitter attenuation) and provides constant propagation delay regardless of the input sampling frequency.

There is no AES/EBU external synchronization mode. The amplified controller's clock always runs at 96 kHz, referenced to its internal clock when on XLR input mode, or on the connected AVB audio stream when on AVB input mode. This ensures low jitter and high audio quality in live conditions (large cable lengths, large number of amplified controllers) while preventing phase shift, as required for line source systems.

Digital domain benefits

Keeping the signal in the digital domain provides the following benefits (with any digital mixing desk or any audio device) compared to the analog signal distribution:

- Better audio quality by removing one D/A - A/D cycle.
- Optimized level chain by removing the risk of level misalignment between console and amplified controllers.
- Digital signal refreshed at each amplified controller in a daisy-chain.
- Improved maximum cable length. LA2Xi has been tested with up to 300 m / 984 ft of two models of AES/EBU rated cables (single cuts, digital source signal running at $F_s = 48$ kHz):
 - 1696A from BELDEN INC.
 - OT234H from KLOTZ communications GmbH.

Analog

LA2Xi can be fed with up to four balanced analog audio signals using the four male 3-point terminal blocks (ANA IN A, ANALOG IN B, ANA IN C, and ANALOG IN D).

The input signals can be transmitted to daisy-chained amplified controllers by wiring the inputs of the next unit into two of the same connectors (ANALOG IN B and ANALOG IN D) and using two male 3-point terminal blocks (ANA A LINK and ANA C LINK).¹

To be processed by the DSP, the analog signal must be converted into a digital signal. For this purpose, the LA2Xi amplified controller is fitted with one 32-bit A/D converter with a sampling rate of 96 kHz.

¹ The link port can only operate in AES/EBU mode for serial numbers below 1730003000. From 1730003000 and on, the link port can operate in AES/EBU mode and ANALOG mode.

DSP architecture

The proprietary algorithms allow optimum performance and protection of each individual transducer of the L-Acoustics systems for an even more natural, transparent, and realistic sound experience.

- The DSP engine is a 32-bit floating point DSP at 96 kHz sampling rate providing an enhanced dynamic range since it does not generate calculation clips like a fixed point DSP.
- A dedicated engineering approach combining IIR and FIR filters generates perfectly linearized phase curves and significantly improved impulse responses.
- The 4 × 4 matrix architecture offers flexibility for various system configurations.
- A delay of up to 1000 ms can be set for each output channel.
- The L-DRIVE transducer protection system offers advanced protection by simultaneously monitoring the excursion and the temperature of the transducer.
- With a complete factory preset library and the possibility to create additional user presets, the flash memory provides a quick access to all the usual L-Acoustics speaker system configurations (refer to the **Preset Guide**).

audio path parameters

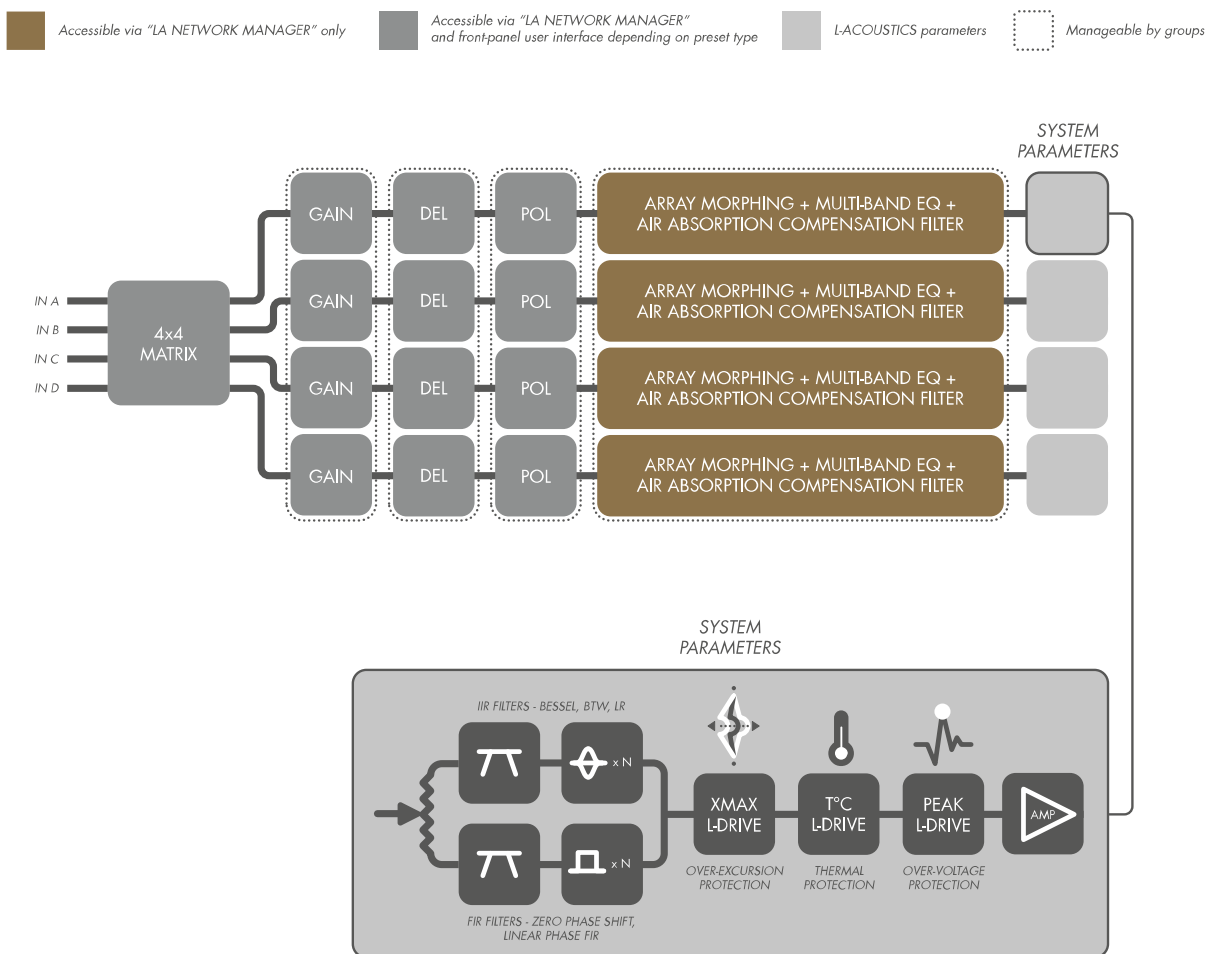

Power supply and amplifier section

The Class D amplification circuits ensure that the LA2Xi is energy-efficient for minimal heat dissipation. LA2Xi delivers (no limiter 200 ms, sine burst < 1% THD, 1 kHz):

- 4 × 640 W at 4 Ω
- 4 × 360 W at 8 Ω
- 4 × 190 W at 16 Ω

LA2Xi is a green amplified controller that relies on a universal Switched Mode Power Supply (SMPS) suitable for mains 100 V AC - 240 V AC ($\pm 10\%$, 50 Hz - 60 Hz). The SMPS features PFC (Power Factor Correction) which maximizes the amplifier efficiency and takes advantage of nearly 100% of the electrical power available with a very high tolerance to unstable mains. This represents a reduction of the electrical power requirements (cable gauge, power conditioning, etc.) for substantial savings.

Speaker outputs

LA2Xi features two female 4-point terminal blocks for loudspeaker outputs.

The terminal blocks can be used in a single-ended (SE) configuration, a bridge-tied load (BTL) configuration, or a parallel bridge-tied load (PBTL) configuration. Using the bridge operating modes improves maximum SPL on large loudspeakers, but reduces the maximum number of loudspeaker enclosure per output and per amplified controller. For the enclosure drive capacity per amplified controller, refer to the **Amplification reference** technical bulletin or the **Preset guide**.

Maximum SPL

Peak level measured at 1 m, under free field conditions for full range loudspeakers and half space conditions for subwoofers, using pink noise with crest factor 4 (preset specified in brackets).

	LA2Xi			LA4X	LA8	LA12X
	SE	BTL	PBTL			
X4i ([X4])	116 dB	—	—	116 dB		
5XT ([5XT])	121 dB	—	—	121 dB		
X6i ([X6i])	122 dB	123 dB	—	123 dB		
X8 ([X8])	125 dB	129 dB	—	129 dB		
X8i ([X8i])	125 dB	129 dB	—	129 dB		
X12 ([X12])	131 dB	136 dB	—	136 dB		
X15 HiQ ([X15])	133 dB	—	—	138 dB		
Syva ([SYVA])	130 dB	137 dB	—	137 dB		
Soka ([SOKA])	128 dB	130 dB	—	130 dB		
ARCS Wide ([ARCS_WIFO])	131 dB	137 dB	—	137 dB		
ARCS Focus ([ARCS_WIFO])	133 dB	139 dB	—	139 dB		
A10(i) Wide ([A10])	133 dB	137 dB	—	137 dB		
A10(i) Focus ([A10])	136 dB	140 dB	—	140 dB		
A15(i) Wide ([A15])	136 dB	141 dB	—	141 dB		
A15(i) Focus ([A15])	139 dB	144 dB	—	144 dB		
Kara II(i) ([KARA II 70])	137 dB	—	—	142 dB		
Kara(i) ([KARA])	136 dB	—	—	141 dB		
Kiva II ([KIVA II])	133 dB	138 dB	—	138 dB		
KS28 ([KS28_100])	136 dB	—	143 dB	—	—	143 dB
SB28 ([SB28_100])	136 dB	—	142 dB	—	142 dB	

	LA2Xi			LA4X	LA8	LA12X
	SE	BTL	PBTL			
KS21(i) ([KS21_100])	131 dB	138 dB	—	138 dB		
SB18 (Ili) ([SB18_100])	133 dB	138 dB	—	138 dB		
SB15m ([SB15_100])	131 dB	137 dB	—	137 dB		
SB10i ([SB10_100])	120 dB	122 dB	—	122 dB		
SB6i ([SB6_100])	113 dB	—	—	113 dB		
Syva Low ([SYVA LOW_100])	131 dB	—	—	137 dB		
Syva Sub ([SYVA SUB_100])	123 dB	128 dB	—	128 dB		

Speaker protection

The L-DRIVE transducer protection system provides a dual analysis of both signal intensity and voltage in real-time and RMS. Under extreme conditions, when component membranes reach the over-excursion zone or if the coil temperature reaches a critical point, L-DRIVE is activated and acts as a power regulator.

As a result, the amount of power delivered at any channel is adjusted to the dynamic and thermal capacity of each individual transducer.

Monitoring and control

User interface

The LED display provides real-time monitoring functionalities:

- power
- L-NET network
- status
- mute, level, limit, clip, and error for each output



Refer to section [Operation](#) (p.33) for detailed operating instructions.

L-NET remote control network

Remote control of processors and amplified controllers requires setting up a private local area Ethernet network to interconnect up to 253 units (and additional devices such as Ethernet switches / AVB bridges) with a single control computer. This Ethernet network, called L-NET, uses L-COM PROTOCOL, a proprietary communication protocol based on TCP/IPv4.

The integration of the L-NET Ethernet-based network, with its high speed data transfer protocol up to 1 Gb/s, allows up to 253 amplified controllers to be controlled and monitored in real-time from LA Network Manager.

Multiple network topologies such as daisy-chain, star, and hybrid are configurable. The computer running LA Network Manager and the amplified controllers are connected to each other using industry standard CAT5e U/FTP cables (or higher category) fitted with RJ45 connectors.

The LA2Xi connects to the network via the two Ethernet etherCON[®] I/O sockets located on its rear panel.



Refer to the **LA Network Manager** Help for detailed operating instructions.

Third party management solutions

L-Acoustics provides SNMP support to facilitate the integration via third-party control and monitoring systems.

L-Acoustics is a certified member of the Crestron® and Extron® partner programs, and provides software modules allowing control integration into their automation systems.

L-Acoustics provides a plug-in for control and monitoring of LA2Xi, LA4X, LA7.16i, and LA12X on the QSC Q-SYS platform.

Inspection and preventive maintenance

How to do preventive maintenance

Inspect the product periodically as indicated, and after any corrective maintenance operation.

Structure and cleanness

Before and after each deployment (touring applications), or at least once a month (fixed installations):

- [CHK - External structure](#) (p.18)
- [CHK - Cleanness](#) (p.19)

Functionalities

At least once a year:

- [CHK - Normal start-up sequence](#) (p.19)
- [CHK - Network functionalities and firmware](#) (p.19)

CHK - External structure

The  indicates a visual inspection.

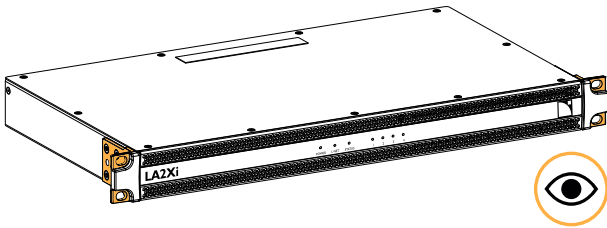

side brackets are present and not damaged

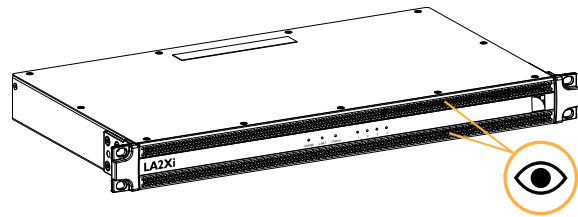

front grills are clean and not damaged
see also [CHK - Cleanness](#) (p.19)

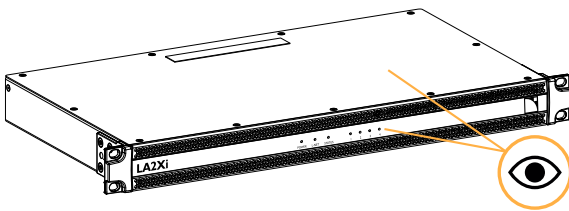

chassis and LEDs are not damaged

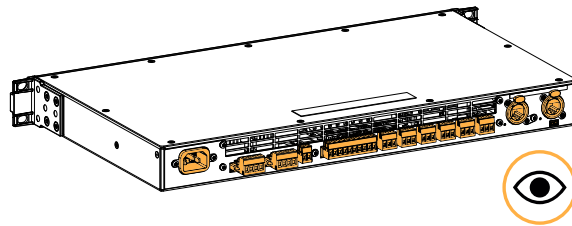

connectors and paired connectors are not damaged

CHK - Cleanness

Equipment

- air blower

Procedure

Clean the amplified controller through the front grill with an air blower.

CHK - Normal start-up sequence

Procedure

1. Plug the amplified controller to mains.
2. Check that all the LEDs light up in orange during the start-up sequence.
3. Check that fan noise can be heard for a few seconds during the start-up sequence.

CHK - Network functionalities and firmware

Equipment

- computer with LA Network Manager version 3.2.1 minimum
- appropriate network cable

Procedure

1. Connect the Ethernet port 1 of the amplified controller to an Ethernet port of a computer running LA Network Manager.
Use the CAT5e U/FTP cable.
2. Run LA Network Manager.
3. Check that the amplified controllers are detected as online Units.
Refer to the **LA Network Manager Help**.
4. Check that all LA2Xi in the system run the same version of the firmware, and that it matches with the version of LA Network Manager in use.
Refer to the **LA NWM and Firmware Compatibility Issues** technical bulletin.
5. If convenient, update LA Network Manager and the firmware to the latest versions.
 If using a third-party control system such as Crestron or QSC Q-SYS, check that updating the firmware does not break compatibility.

Installation

Mounting

The LA2Xi is one rack units high (1U) and can be mounted in an EIA-standard 19" rack using the four points on the front panel. Use the fixing material provided by the rack manufacturer to mount the amplified controller to the rack front rails.

LA2Xi dimensions

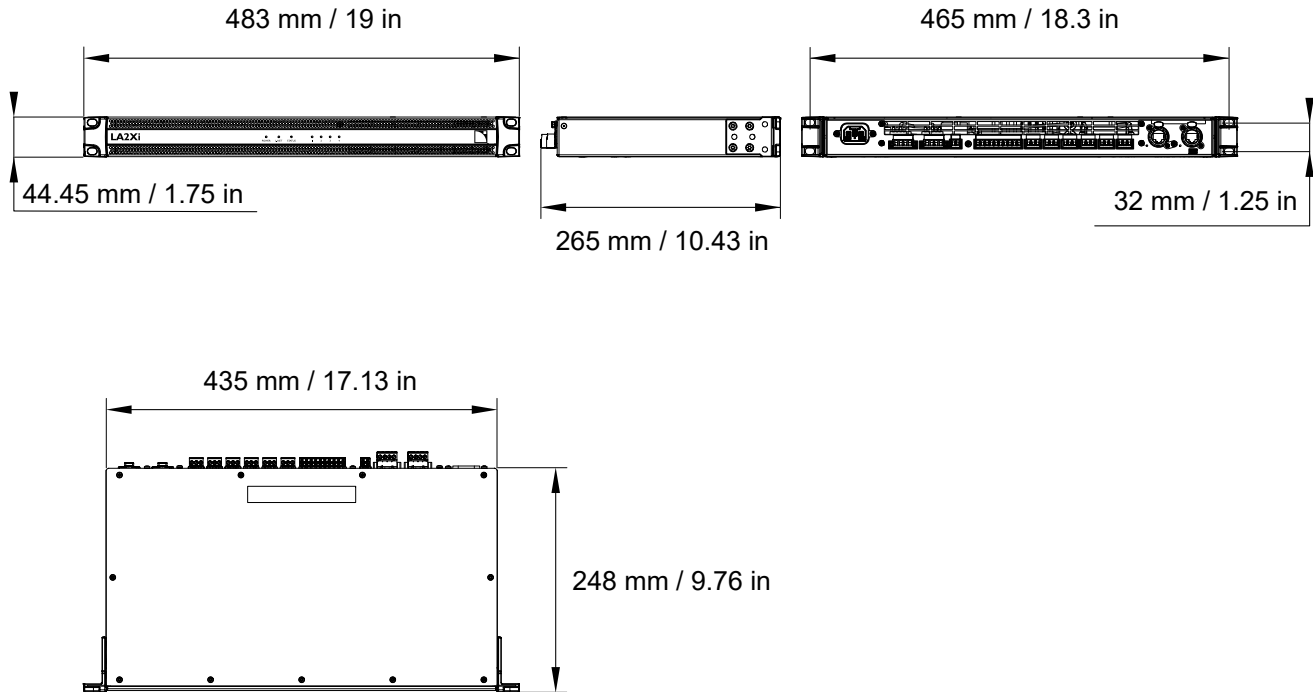

LA2Xi is not compatible with L-Case.

Ventilation

To maintain moderate operating temperatures, the LA2Xi is equipped with fans and grills providing front to rear airflow.



Ventilation instructions

Install the controller in an open area so that the front and rear panels are located at a minimum distance of 30 cm / 12 in from any external object or structure.

Ensure the front grill is clean and dirt free.

Do not block the front and rear ventilation grills.

Ventilation when rack-mounted

Do not block the ventilation grills with front or back panels or doors. If not possible, use a forced-ventilation system.

When stacking more than one controller in a rack, mount them directly on top of each other or close any open space in the rack with blank panels.

General Purpose I/O (GPIO)

The amplified controller's rear side features a 10-point terminal block General Purpose I/O (GPIO).

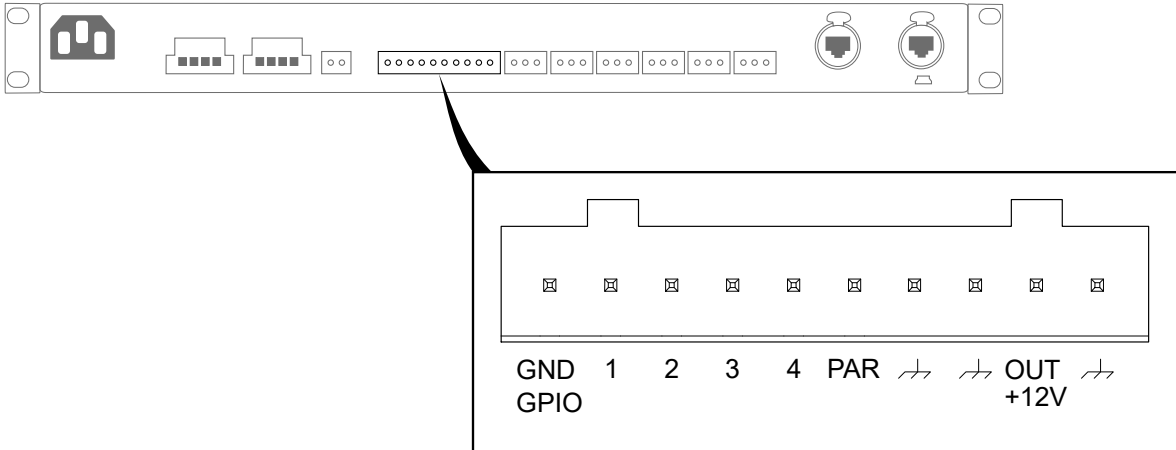

GND	ground
1	input or output
2	
3	
4	
PAR	Connect to a chassis ground pin for PBTL bridging. Refer to Speaker (p.31).
⎓	chassis ground
⎓	chassis ground
OUT +12V	Used to power a contact relay, 45 mA maximum.
⎓	chassis ground

GPIO can be configured using LA Network Manager. For more information, refer to the **LA Network Manager** Help.

Connecting to AC mains

Electrical specifications

AC mains specifications

-  **Verify the electrical conformity and compatibility of the mains supply.**
 Only connect the product to an AC power outlet rated 100-240 V, 50-60 Hz, with the following current values:
 100 V (Japan): 20 A
 120 V (North America): 15 A
 220-240 V (EU): 10 A
 WARNING: The product is of Class 1 construction and shall be connected to a mains socket outlet with a Protective Earth connection.

Three-phase circuit

-  **When the product is used in a three-phase circuit, verify the electrical conformity and compatibility of the three-phase circuit.**
 Verify that the three phases work, and balance the loads between the three phases.
 Verify that the neutral and earth work.
 Never try to emulate a 230 V circuit connecting an apparatus to two live wires of a 120 V three-phase circuit.
 Never try to emulate a 200 V circuit connecting an apparatus to two live wires of a 100 V three-phase circuit.

Circuit breaker

-  **Always interconnect a circuit breaker between the product and the mains supply.**
 Use these references, or equipment with equivalent characteristics:
 100 V (Japan): 20 A Terasaki S125-NF 1P
 120 V (North America): 15 A Square D QO
 220-240 V (EU): 10 A Type C

Planning the power of the electrical generator

-  **Electrical generator**
 You must power on the generator before powering on the product.

LA2Xi draws up to 6 A from 230 V.

A typical generator has a power factor of 0.8 and should operate at 70% load for good efficiency.

The kVA provision for one LA2Xi should therefore be:

$$(6 \text{ A} \times 230 \text{ V}) / (0.8 \times 70\%) = 2.4 \text{ kVA}$$

This calculation is an example using typical values. It can be adapted using the table in section [Power consumption](#) (p.24).

Power cord

The removable power cord is fitted with a V-Lock compatible IEC connector at one end, and a country-specific plug at the other end.

type	plug	cable ratings	live	neutral	ground
CE	CEE7/VII, earthed				
CN	GB 2099, earthed	10 A / 250 V	brown	blue	green/yellow
INT	bare ends (local power plug to be fitted)				
JP	JIS 8303, earthed	12 A / 125 V	black	white	green/yellow
US	NEMA 5-15, earthed	10 A / 125 V			green



Strictly apply the specific safety regulations of the country of use.

Do not defeat the ground connection of the supplied power cord using an adaptor or any other method.

A suitable plug must be wired to the INT power cord.

Verify that the plug conforms to the specific voltage and current rating given in section [Electrical specifications](#) (p.22).

Plugging the amplified controller

How to plug the amplified controller to the AC mains.

Procedure

- First, connect the IEC connector to the amplified controller mains panel.

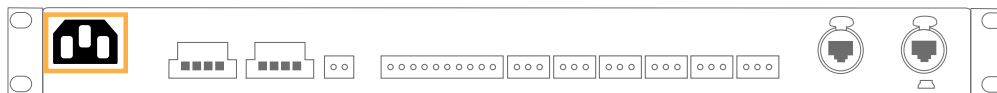

- Then, connect the power plug to the mains socket.

Power consumption

The LA2Xi power requirements depend on the load impedance and the signal level.

Mains input power and current draw (all channels driven)

In SE mode

Maximum output power	4 × 190 W at 16 Ω	4 × 360 W at 8 Ω	4 × 640 W at 4 Ω
1/3 output power (-5 dB)	1.9 A / 330 W	2.9 A / 590 W	4.7 A / 1020 W
1/8 output power (-9 dB)	1.2 A / 160 W	1.6 A / 260 W	2.3 A / 440 W

In BTL mode

Maximum output power	2 × 710 W at 16 Ω	2 × 1260 W at 8 Ω
1/3 output power (-5 dB)	2.9 A / 590 W	4.7 A / 1020 W
1/8 output power (-9 dB)	1.6 A / 260 W	2.3 A / 440 W

In PBTL mode

Maximum output power	1 × 780 W at 16 Ω	1 × 1400 W at 8 Ω	1 × 2550 W at 4 Ω
1/3 output power (-5 dB)	1.9 A / 330 W	2.9 A / 590 W	4.7 A / 1020 W
1/8 output power (-9 dB)	1.2 A / 160 W	1.6 A / 260 W	2.3 A / 440 W

Current values given for mains rated at 230 V. Multiply by:

- 2.3 for 100 V
- 1.92 for 120 V
- 1.15 for 200 V

Output power references

A third (1/3) of the maximum output power corresponds to the worst case scenario of a program source using highly compressed music or pink noise with amplified controller driven to clip level.

An eighth (1/8) of the maximum output power corresponds to a loud music program with a small dynamic range and 9 dB of headroom (IEC standard power rating).

Mains input power and current draw in Idle and Standby modes

Idle	0.5 A / 27 W
Standby	0.4 A / 16 W

Due to line filter operation, power factor is < 0.3 in Idle mode, and < 0.2 in Standby mode. Current values above are given for mains rated at 230 V and decrease with lower mains.

Heat power calculation

If a 4 Ω load is connected to each output channel of the LA2Xi in SE mode, each channel delivers up to 640 W.

With a standard use at one eighth (1/8) of full power (9 dB headroom), the power delivered per channel is:

$$640 \text{ W} / 8 = 80 \text{ W}$$

Therefore, a total power of:

$$4 \times 80 \text{ W} = 320 \text{ W}$$

According to the table in section [Power consumption](#) (p.24), the LA2Xi power consumption is 440 W. The heat power produced is then (difference between power consumption and output power):

$$440 \text{ W} - 320 \text{ W} = 120 \text{ W}$$

24 V DC Input

The amplified controller's rear side features a 2-point terminal block for external powering of the DSP in case of mains failure.

In case of power failure, 24 V DC input (if used) allows for a faster recovery of the amplified controller and continued reporting and monitoring of the network and DSP.

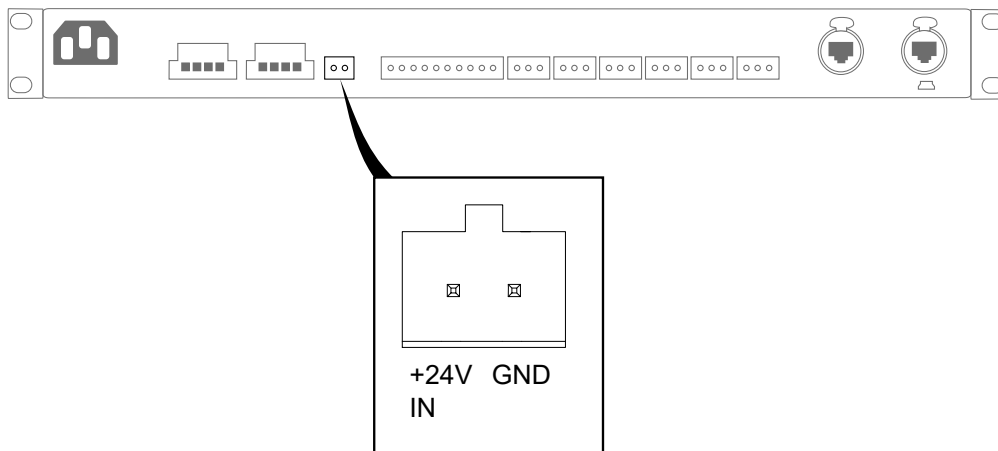

The external power supply should be rated 24 V DC ($\pm 20\%$) 10 W maximum.

The amplified controller must be connected to the mains for firmware updates. Firmware updates cannot be performed when the amplified controller is solely powered by the 24 V DC input.

Audio and network cabling

Connection panels

The amplified controller's rear side features connectors for audio and network cabling:

1. For connection to the loudspeakers.
2. For connection of the analog and digital (AES/EBU) audio sources, and/or for linking the signals to another amplified controller.
3. For connection to an AVB network, and to be remotely controlled by LA Network Manager.

LA2Xi audio and network connection panels

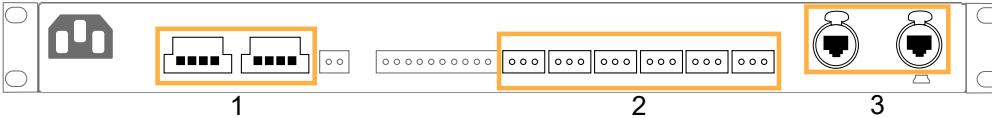

For LA2Xi I/O-CON audio panel, refer to [Appendix A - Optional LA2Xi I/O-CON accessory](#) (p.54).

Speaker connectors

Use the two female 4-point terminal blocks for loudspeaker connection. The connectors are wired as follows:

left 4-point terminal block			both 4-point terminal blocks	
	SE*	BTL*	PBTL*	
Pin 1+	Out 1+	Out 1+	Out 1+	
Pin 1-	Out 1-	N/A		N/A
Pin 2+	Out 2+	N/A		N/A
Pin 2-	Out 2-	Out 2-		Out 2-
right 4-point terminal block				
	SE*	BTL*		
Pin 3+	Out 3+	Out 3+	Out 3+	
Pin 3-	Out 3-	N/A		N/A
Pin 4+	Out 4+	N/A		N/A
Pin 4-	Out 4-	Out 4-		Out 4-

*SE: single-ended. BTL: bridge-tied load. PBTL: parallel bridge-tied load. Refer to [Speaker](#) (p.31).

Analog/Digital output connectors

Use the six male 3-point terminal blocks for digital (AES/EBU) and analog signal cabling.

The connectors are wired as follows (from left to right):

- pin 1: + signal
- pin 2: - signal
- pin 3: shield

Analog inputs

ANA IN A, ANALOG IN B, ANA IN C, and ANALOG IN D can receive up to four analog signals (when setting the analog input mode). The headroom of the input circuits is high enough to accept the maximum output level from almost any line-level signal source (up to 22 dBu).

The input signals can be transmitted to daisy-chained amplified controllers using ANA A LINK, ANA C LINK¹, ANALOG IN B, and ANALOG IN D.

AES/EBU inputs

Supported digital input format

Standards	AES/EBU (AES3)
Sampling frequency (Fs)	44.1, 48, 88.2, 96, 176.4, or 192 kHz
Word length	16, 18, 20, or 24 bits
Synchronization	signal resampled to internal clock at 96 kHz

AES IN A&B and AES IN C&D can receive up to four digital signals (when setting the AES/EBU input mode).

Each LINK connector is electronically buffered to allow daisy-chaining any number of amplified controllers. It also features a failsafe relay to ensure wiring continuity in case of amplified controller shutdown.

Ethernet connectors

Use the two etherCON connectors for the remote control of LA2Xi over the L-NET network using LA Network Manager. The etherCON connectors are AVB-capable.

In normal network mode, the two etherCON connectors are part of an internal AVB switch, and allow for daisy-chaining of additional devices.

In redundancy mode, the two etherCON connectors are independent: the LINK/ACT 1 connector is used for the primary network, and the LINK/ACT 2 connector is used for the secondary network.

¹ The link port can only operate in AES/EBU mode for serial numbers below 1730003000. From 1730003000 and on, the link port can operate in AES/EBU mode and ANALOG mode.

Analog audio

i Balanced cables

Symmetrical (balanced) shielded cables are highly recommended as balanced signals are less sensitive to AC hum and radio interference.

Unbalanced lines may add noise especially over long cable runs.

In a daisy-chain layout, the input signals can be transmitted to daisy-chained amplified controllers using the same connectors for B&D, and the link connectors for A&C.¹

daisy-chaining analog audio

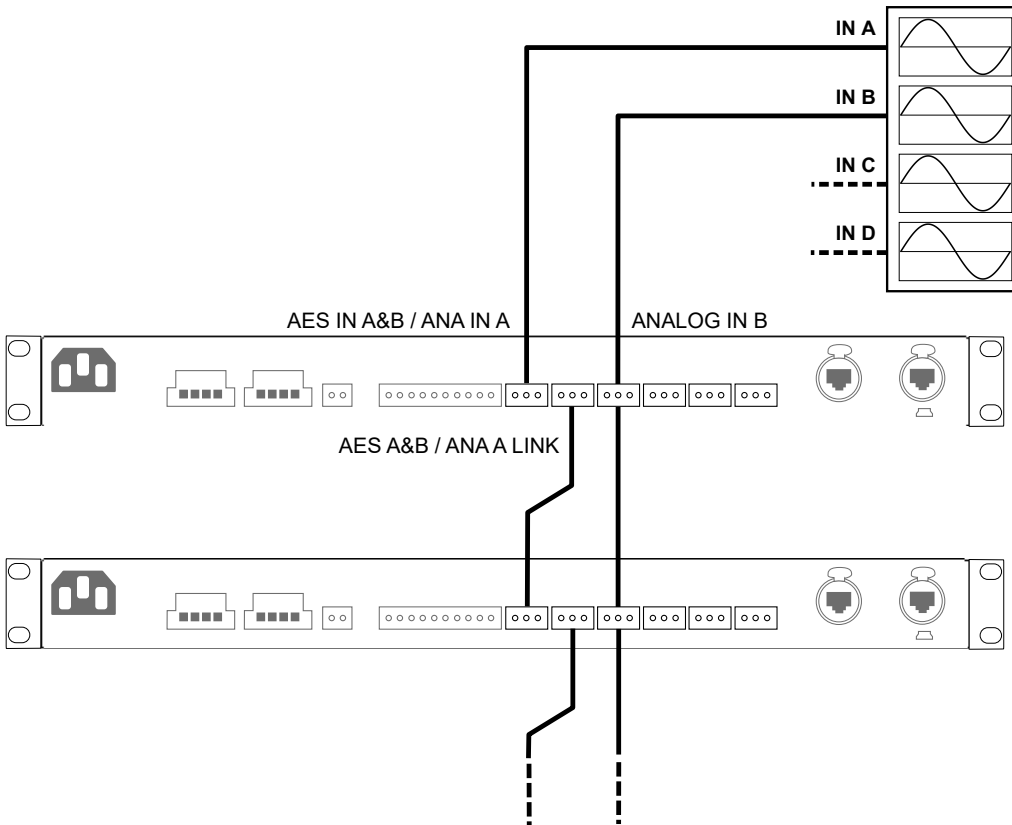

! Analog daisy-chain and LA4/LA8 with power off or in standby

In an analog daisy-chain, LA4 and LA8 with power off or in standby cause sound distortion at high input levels to the other amplified controllers they are connected to.

Make sure all LA4 and LA8 are powered on and in operating (not in standby) mode, or disconnect them from the daisy-chain.

¹ The link port can only operate in AES/EBU mode for serial numbers below 1730003000. From 1730003000 and on, the link port can operate in AES/EBU mode and ANALOG mode.

Digital audio

In a daisy-chain layout, AES LINK A&B and AES LINK C&D feed the input signals to the next amplified controller in the signal chain.

daisy-chaining digital audio

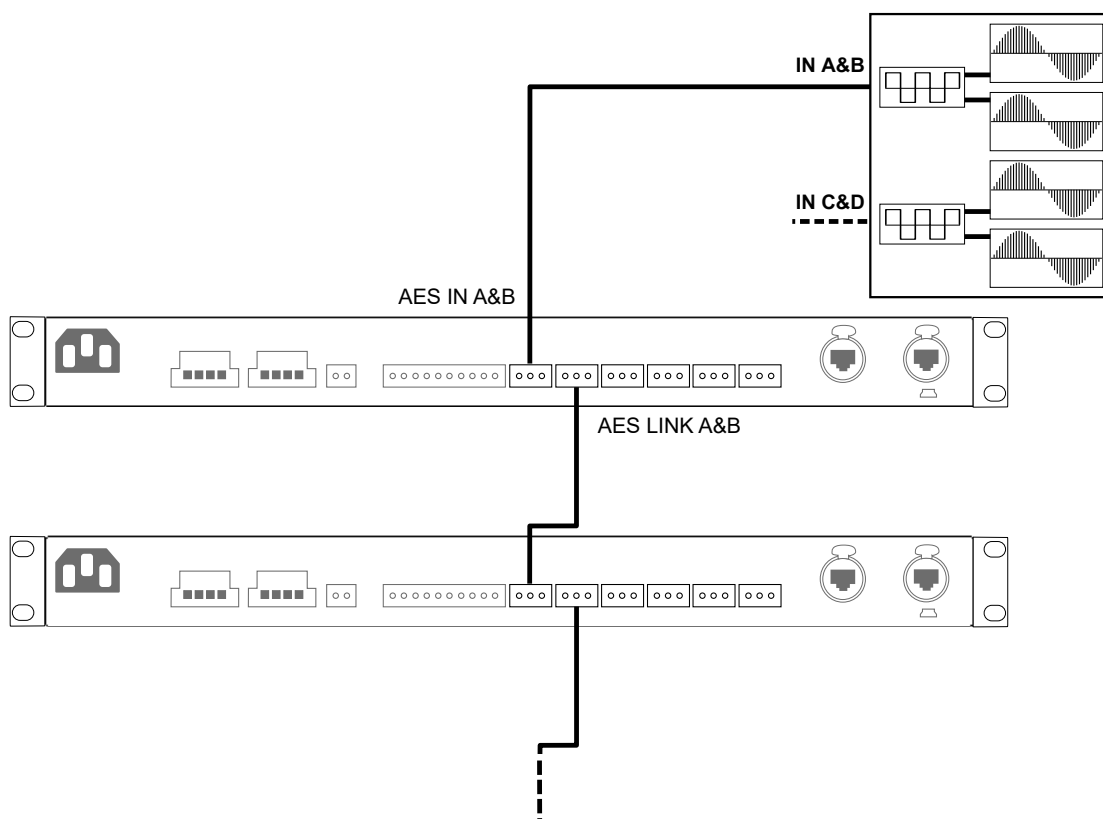

Cables for AES/EBU digital audio

AES3 specifies that the nominal characteristic impedance of cables used for AES/EBU digital audio transmission shall be $110 \Omega \pm 20\%$, and closer tolerances allow for increased transmission reliability over long lengths or higher sampling rates.

Therefore, it is highly recommended to use high-quality AES/EBU rated cables only, although certain cables designed for balanced analog audio prove to be acceptable at 48 kHz sampling rate over very short distances.

It is recommended to use single lengths of cable between AES/EBU outputs and inputs. Using several shorter cables joined together reduces performance. If it is not possible to use single lengths, it is required to use the same model of cable between two AES/EBU interfaces.

In case an amplified controller shuts down, the failsafe relay makes a passive connection between the AES/EBU IN port and the LINK port to maintain continuity. However the signals are no longer refreshed for the next amplified controller, so that the input cable and the link cable must be considered as a unique input cable with regard to the maximum supported length.

In case of transmission losses, try to reduce the sampling frequency of the digital audio source. Moreover, as a general rule, avoid using sources rated beyond 96 kHz, as the maximum possible cable length is reduced, while the additional information is discarded by the SRC to 96 kHz.

L-NET/AVB



Do not create loops in the network setup.



In daisy-chain networks, always place LA4X with hardware version* ID1, ID2 or ID3, LA4, and LA8 after any other type of amplified controller.

These amplified controllers are equipped with former generation 100 Mb/s Ethernet ports that cannot communicate with Ethernet ports of different capabilities, creating detection issues in LA Network Manager.

*The LA4X hardware version is visible in the MONITORING & INFO menu (HARDWARE INFO section).

Use the two etherCON connectors on the rear panel to connect LA2Xi both to L-NET and to an AVB network. Real-time audio traffic and control traffic are automatically managed by AVB on the same network.

LA2Xi supports AVB Milan in normal mode and in redundant mode. In Redundant mode, LA2Xi must be connected in star topology, port 1 being used for the primary network, port 2 being used for the secondary network. In normal mode, daisy-chain, star, or hybrid topologies are supported.

Refer to the **LA Network Manager** Help for network setup.

Remote control of processors and amplified controllers requires setting up a private local area Ethernet network to interconnect up to 253 units (and additional devices such as Ethernet switches / AVB bridges) with a single control computer. This Ethernet network, called L-NET, uses L-COM PROTOCOL, a proprietary communication protocol based on TCP/IPv4.

An IP address is a unique identifier for a network device on a given IP network. In IPv4 networking, it is made of 4 bytes (32 bits). An IP address is composed of a subnet address and a host address. The host address serves as a unique device identifier on the subnet. The subnet mask determines how many bits define the subnet address, and how many define the host address.

By convention, the first possible number of the host address is reserved to designate the subnet, and the last number is reserved to communicate with all devices of the subnet (IP broadcast address).

The factory default IP settings of all L-Acoustics devices are:

- IP address: 192.168.1.100
- Subnet address: 192.168.1.0/24
- IP broadcast address: 192.168.1.255
- Subnet mask: 255.255.255.0

With these settings, the first three bytes of the IP address (192.168.1) define the subnet address, and the last byte is the host address (100).

In general, it is recommended to:

- Use the default subnet address and subnet mask.
- Edit the device host address to provide a unique identifier to each unit: use consecutive IP addresses starting from 192.168.1.**1** up to 192.168.1.**253**.
- Set the control computer to 192.168.1.**254**.

However, it is possible to configure other IP settings when required by network administration. Subnet mask may be defined from 255.0.0.0 to 255.255.255.0, and the IP and gateway addresses must both belong to one of the following IP ranges (standards for Private Local Area Networks):

- 10.0.0.1 to 10.255.255.254
- 100.64.0.1 to 100.127.255.254
- 172.16.0.1 to 172.31.255.254
- 169.254.0.1 to 169.254.255.254 (not recommended)
- 192.168.0.1 to 192.168.255.254



LA Network Manager and its host computer must be using the same subnet and Subnet mask as the units.

In AVB redundant mode, the host address is always made identical for both the Primary and the Secondary network. The subnet address of the Secondary network is that of the Primary + 1. For example, with default settings:

- Primary port: 192.168.**1**.100
- Secondary port: 192.168.**2**.100

The subnet mask setting always applies to both networks. When using smaller subnet masks, the host address is also made identical. For example:

- Primary port: 172.**16**.1.100
- Secondary port: 172.**17**.1.100

The Gateway address is only available for the Primary network.

For subnet settings, refer to the **LA Network Manager** Help.

Speaker

Use the two female 4-point terminal blocks to connect an enclosure to the amplified controller in a single-ended (SE), bridge-tied load (BTL), or a parallel bridge-tied load (PBTL) configuration.

Using the bridge operating modes improves maximum SPL on large loudspeakers, but reduces the maximum number of loudspeaker enclosure per output and per amplified controller. For the enclosure drive capacity per amplified controller, refer to the **Amplification reference** technical bulletin or the **Preset guide**. For the maximum SPL, refer to [Maximum SPL](#) (p.15).

i Using multicore loudspeaker cables

Never connect more than one amplified controller on a single multicore loudspeaker cable.

Connecting several amplified controllers may cause audible interferences on the loudspeaker enclosures when the amplified controllers are in idle mode, even when muted.

Procedure

1. Identify the required operating mode, then check the state of the PAR pin. It must be:
 - a) Disconnected for SE mode (SE | SE | SE | SE) or BTL modes (SE | SE | BTL, BTL | SE | SE, or BTL | BTL).
 - b) Connected to a ground pin for PBTL mode.

Refer to [General Purpose I/O \(GPIO\)](#) (p.21) to locate the pins.

2. Connect the enclosure(s):



Strictly follow the loudspeaker wiring diagrams.

Risk of unwanted noise and errors (bridge modes not operational).

Risk of acoustic cancellations and lack of audio source localization (discrepancy in loudspeaker polarities).

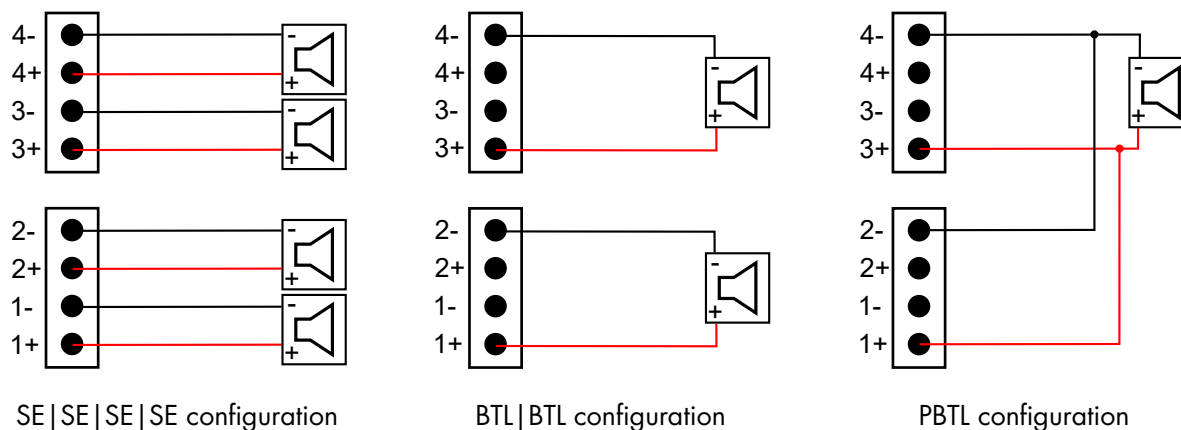

Unused pins do not need to be connected.

For more enclosure-specific cabling schemes, refer to the owner's manual of the enclosure.

3. Turn on LA2Xi.

If already turned on, either reboot, standby / wake up, or unplug/replug the power cord to apply the changes.

4. Connect LA2Xi to LA Network Manager:

- a) If using an existing session, solve any Unit Type conflicts in the Unit Matcher.
- b) If starting a new session, select the appropriate mode for each unit in the Operating Mode Selector.

Connector references

usage	number	type	reference
GPIO	1	male 10-point terminal block	Phoenix Contact MSTB 2,5/10-ST-5,08 – 1757093
24 V DC input	1	male 2-point terminal block	Phoenix Contact MSTB 2,5/2-ST-5,08 – 1757019
loudspeaker output	2	female 4-point terminal block	Phoenix Contact IC 2,5/4-STF-5,08 – 1825336
audio input/link	6	male 3-point terminal block	Phoenix Contact MSTB 2,5/3-ST-5,08 – 1757022

The connectors have a pitch of 5.08 mm (0.200").

The Phoenix Contact connectors are compatible with cable gauges of up to 2.5 mm².

Use a 3.5 mm slotted screwdriver for terminal blocks to secure the loudspeaker output connectors to the amplified controller. Reference: Phoenix Contact SZS 0,6X3,5 – 1205053.

PHOENIX CONTACT is a trademark of PHOENIX CONTACT GmbH & Co. KG.

Operation

Powering on/off

LA2Xi turns on immediately when plugged, and turns off immediately when unplugged (no on/off switch), refer to [Plugging the amplified controller](#) (p.23).

If power is lost, the amplified controller shuts down, but all parameters are restored when the amplified controller is powered again.

The POWER LED is lit in orange when the amplified controller is in standby mode.



Use LA Network Manager to set the amplified controller to standby or back to operating mode. Refer to the **LA Network Manager** Help.

Interpreting the front panel LEDs

L-NET

The L-NET LED on the front panel displays the L-NET status.



- green: when LA2Xi is remotely controlled by LA Network Manager (refer to the **LA Network Manager** Help).
- orange: when LA2Xi is remotely controlled by a third-party software.
- off: when no software remotely controls the amplified controller.

STATUS

The STATUS LED on the front panel displays the state of the amplified controller.



- green: when the LA2Xi operates normally
- orange: during firmware update
- red: when a fault is detected in the LA2Xi circuitry, indicating a protection system is active

Refer to the **LA Network Manager** Help for more information on errors.

Meters

The four LED meters display the state of the corresponding output channel.

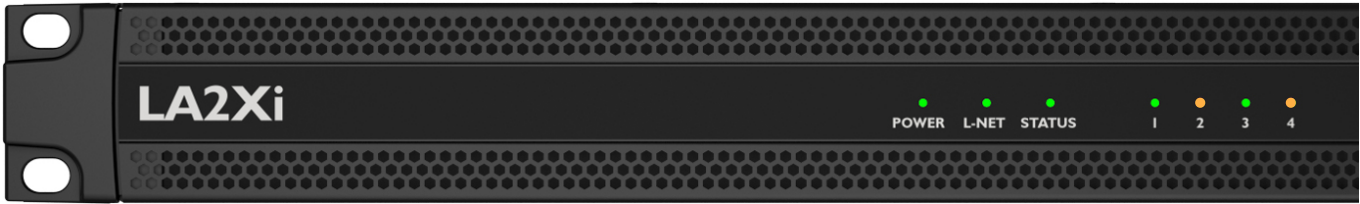

red	continuous	the output voltage reaches the maximum level (signal clip)
	fade in/out	the output channel is muted
	1 s blink	there is an error on the output channel
orange	continuous	the L-DRIVE limiter is activated with gain reduction of at least 3 dB
	blink	during identification from LA Network Manager
green	high	the output voltage reaches 20 dB below the maximum level
	low	the output voltage reaches 60 dB below the maximum level
	progress from 1 to 4	during firmware update
off		the output voltage is more than 60 dB below the maximum level

Other operations

The following operations can only be performed from software applications.

	LA Network Manager	USB Terminal¹	L-Acoustics Device Scanner
Connection type	L-NET network	USB ²	network
Edit IP address	yes	yes	yes
Edit subnet mask	–	yes	yes
Select redundancy mode	yes	yes	yes
Select spanning tree (RSTP) mode	yes	–	–
Configure GPIO	yes	–	–
Manage presets and edit their parameters	yes	–	–
Edit input settings	yes	–	–
Select output mode	yes	–	–
Set in standby / wake up mode	yes	–	–
Reboot	yes	–	yes
Edit group parameters	yes	–	–
Monitor	temperature, mains voltage, firmware version, library version	firmware version, MAC address, serial number	firmware version, MAC address, serial number
Enable settings protection	yes ³	–	–
Enable HTTP authentication	–	–	yes
Mute/Unmute	yes	–	–
Update firmware ⁴	yes	–	–
Identify	yes	–	yes
Edit name	–	–	yes
Retrieve logs	yes	–	yes
Reset to factory default settings	–	yes	–

Refer to the **LA Network Manager** help, the **L-Acoustics Device Scanner** user guide, and the **GPIO** technical bulletin for more information.

¹ The USB Terminal utility is available in LA Network Manager.

² Disconnect the amplified controller from the L-NET network or switch LA Network Manager to offline mode when making changes from the USB Terminal.

³ Settings Protection does not prevent actions done from the **USB Terminal** utility. Take measures to restrict access to the USB port of the amplified controller.

⁴ The amplified controller must be connected to the mains. Firmware updates cannot be performed when the amplified controller is solely powered by the 24 V DC input.

Corrective maintenance

Introduction

This section is intended for end users and gathers the level 1 procedures.

⚠ This manual contains the maintenance operations authorized for the end user.

Performing another operation exposes to hazardous situations.

Troubleshooting and diagnosis (p.38)

This section contains the diagnosis tables and procedures to identify the issues and how to address them.

Exploded view (p.44)

This illustration gives an overview of the order in which the elements must be disassembled and reassembled. Each assembly refers to the corresponding D/R procedure and the necessary repair kit(s).

Disassembly and Reassembly procedures (p.45)

This section contains the maintenance procedures for each assembly identified in the exploded view.

Inspection and preventive maintenance (p.18)

These checks allow to detect an issue. The preventive maintenance must be performed regularly.

Equipment and tools

Tools

Before performing maintenance on this product, make sure all the tools listed are available. References are given for FACOM® products in this table. Other manufacturers can be used.

name	reference	distributor
set of 6-point 1/4" sockets	RL.NANO1 / R.360NANO	FACOM
torque screwdriver (0.5 - 2.5 N.m)	A.402	FACOM
smoothing tool	-	-

Screw repair kit

This repair kit contains spares to replace lost or damaged screws while performing maintenance operations on LA2Xi.

G03615

KR external screws LA2Xi

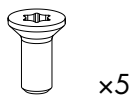

x5

S100085

M4x10 Torx



x5

S100236

M3x10 Torx

G03606

KR internal screws LA2Xi

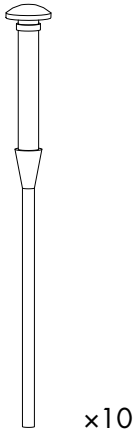

FT010126
silicone rubber fastener



S100219
M2.5x8 Torx

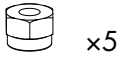

S120
M3 hex lock nut

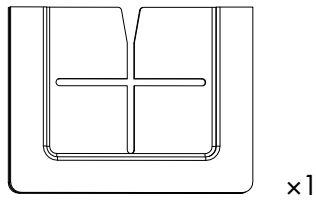

FT882
large cable grommet

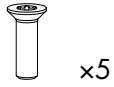

S100236
M3x10 Torx



S100220
M3x6 Phillips

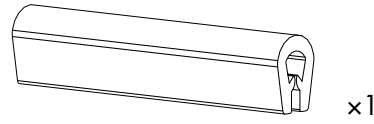

103118
edge protection

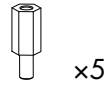

FT888
M3x10 hex spacer

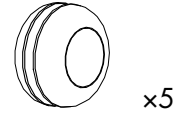

FT03451
cable grommet

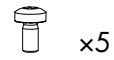

S100177
M3x6 Torx

Troubleshooting and diagnosis

For any issue, consider the diagnosis tables for the possible causes and inspection procedures (if any).

Before applying any procedure, consider the [Exploded view](#) (p.44) to get acquainted with the disassembly/reassembly procedures to perform before and after.

LED issues

Refer to [Interpreting the front panel LEDs](#) (p.33).

Refer to the LA Network Manager help for software use.

none of the LEDs work

possible cause	diagnosis / procedure
power cord not connected	<ul style="list-style-type: none"> • Check that the power cord is connected to mains. • Check that the power cord is properly connected and locked to the amplified controller.
mains failure or incompatible voltage	<p>Check that mains are available and that voltage is compatible (100 V AC - 240 V AC \pm 10%, 50 Hz - 60 Hz).</p> <p>Check that the circuit breaker is closed.</p>
power cord damaged	Inspect the power cord. If necessary, replace it.
other causes	Contact L-Acoustics.

some LEDs do not work (when the other LEDs work)

Contact L-Acoustics.

the STATUS LED is red

Connect the amplified controller to a computer running LA Network Manager and check the Message Center. Refer to [Error messages](#) (p.42).

L-NET network issues

impossible to connect an amplified controller to the L-NET network

Refer to the LA Network Manager help for software use.

possible cause	diagnosis / procedure
LA Network Manager set in offline mode	Select the online mode.
selected scanning range does not contain the amplified controller IP address	Include the amplified controller IP address into the scanning range.
amplified controller set with an incorrect IP address, or several amplified controllers set with the same IP address	Set the computer IP address and subnet mask and the amplified controller IP address as indicated in the LA Network Manager help.
L-NET cable is not plugged or incorrectly plugged	Plug and secure appropriate network cables into the L-NET connectors on the amplified controllers to connect it to the other amplified controllers, the computer, or to the Ethernet switch (each of the amplified controller connectors can be equally used as an IN or LINK connector): The ACT/LINK LEDs should turn on. Refer to the LA Network Manager help.
L-NET cable is damaged	Replace any damaged network cable in the network chain.
more than two software clients are already connected to the amplified controller	Disconnect all other software clients.
firmware failure	Restart the amplified controller.
other causes	Contact L-Acoustics.

Sound issues

no sound with no error message

(amplified controller is not in standby mode. Refer to the LA Network Manager help)

possible cause	diagnosis / procedure
mains failure	Inspect the mains.
outputs are muted	Unmute the outputs.
incorrect input mode	If the fallback mode is ON, switch it OFF. Select the input mode according to the audio source format (Milan AVB, AES/EBU, analog). If using Milan AVB, check the AVB configuration and parameters.
incorrect preset selection	Select a preset in accordance with the loudspeaker system connected to the outputs.
gain value is too low on the amplified controller	Set an appropriate gain value on channels OUT1 to OUT4. If the AES/EBU input mode is selected, set an appropriate AES/EBU input gain value.
audio source is not plugged, incorrectly plugged, or plugged into the wrong input connector	Plug/Replug and secure each audio source cable into the audio source and the corresponding input connector on the amplified controller.
audio source cable is damaged	Replace the audio source cable.
incorrect settings on the audio source	Set appropriate parameter values on the audio source, in particular the output gain value (refer to the third-party documentation).
non-audible bit stream	Check that the AES/EBU source does not deliver non-audio bit stream (for example encoded audio).
audio source failure	Inspect the audio source for failure. Reminder: A digital audio source can meet the following failures: no clock, loss of lock, invalid audio (validity bit), CRC error, bipolar encoding error, data slip.
loudspeaker not plugged, incorrectly plugged, or plugged into the wrong output connector	Plug/Replug and secure each loudspeaker cable into the loudspeaker and the corresponding output connector on the amplified controller.
loudspeaker cable is damaged	Replace the loudspeaker cable.
loudspeaker is damaged	If only one loudspeaker is connected, inspect it.
other causes	Contact L-Acoustics.

noise, level loss, distorted sound, white noise (no error message)

possible cause	diagnosis / procedure
AES/EBU audio source is connected to an analog input	Check the input signal cabling and check that the input mode has been selected accordingly in LA Network Manager.
gain value too high on the amplified controller	Set an appropriate gain value on channels OUT1 to OUT4. If the AES/EBU input mode is selected, set an appropriate AES/EBU input gain value.
output gain value too high on the audio source	Set an appropriate output gain value on the audio source (refer to the third-party documentation).
switch to the analog fallback mode with incorrect AES/EBU input gain value	Set an appropriate AES/EBU input gain value and inspect the digital audio source for failure. Reminder: A digital audio source can meet the following failures: no clock, loss of lock, invalid audio (validity bit), CRC error, bipolar encoding error, data slip.
incorrect preset selection	Select a preset in accordance with the loudspeaker system connected to the outputs.
audio source cable incorrectly plugged	Unplug the audio source cable and plug it again on the audio source and the amplified controller. Verify with the installer if ground loops can occur.
audio source cable damaged	Replace the audio source cable.
incorrect settings on the audio source	Set appropriate parameter values on the audio source (refer to the third-party documentation).
audio source failure	Inspect the audio source for failure.
loudspeaker incorrectly plugged or plugged into the wrong output connector	Plug/Replug and secure each loudspeaker cable into the loudspeaker and the corresponding output connector on the amplified controller. Verify with the installer if ground loops can occur.
loudspeaker cable damaged	Replace the loudspeaker cable.
loudspeaker is damaged	If only one loudspeaker is connected, inspect it.
other causes	Contact L-Acoustics.

Error messages

When the STATUS LED is red, connect the amplified controller to a computer running LA Network Manager, and check the Message Center.

Refer to the LA Network Manager help for software use.

Component status messages

LA2Xi components are monitored for major or critical errors and faults.

FPGA error	Displayed if the FPGA cannot be initialized. Try to update the firmware. If the issue persists, contact L-Acoustics.
DSP start-up fault	Displayed if the DSP cannot initialize. Try to update the firmware. If the issue persists, contact L-Acoustics.

The controller must be sent to an L-Acoustics representative for maintenance.

Other messages

Update error	Displayed if the firmware update has failed. Try to restart the unit. If the issue persists, check that each L-NET cable is in working order and is correctly plugged on both ends, and relaunch the update process. If the issue persists, contact L-Acoustics.
High temperature on channel # - channel level attenuated	Displayed if temperature at an output channel is above 70°. The signal delivered at the output channel pair is attenuated until temperature returns to nominal conditions.
Fan blocked	Displayed if a fan is faulty. The unit remains operational but there is a risk of temperature rising.
Speaker short-circuit fault detected on channel # - channel muted	Displayed if the unit detects a short-circuit fault in the speaker coil or the input board of the connected enclosure. The output channel is muted to avoid a potential risk of physical harm and further damages to the product. Verify the connected loudspeaker enclosures. Disconnect or replace the faulty enclosure, then unmute the output channel.

For temperature-related messages

possible cause	diagnosis / procedure
room temperature is too high / too low	Make sure room temperature is within amplified controller operating condition range (-5 °C / 23 °F to 50 °C / 122 °F).
inside of amplified controller dusty	Clean the amplified controller with an air blower.
amplified controller is not getting enough cool air	<p>Install the amplified controller in an open area so that the front and rear panels are not blocked by an external object or structure.</p> <p>If rack-mounted:</p> <ul style="list-style-type: none"> • Do not block the ventilation grill with front and back panels or doors, or use a forced ventilation system. • When stacking more than one amplified controller, mount them directly on top of one another or close the free spaces with blank panels.
channel resources are solicited to their limits	<p>Monitor the channel LED:</p> <p>In case of persistent high level or clip, reduce the audio source output level (refer to the third-party documentations) or the gain value on the channel.</p>
loudspeaker impedance too low	Check that nothing causes a short-circuit at the output (incorrect cabling scheme, damaged cable or short-circuit in the speaker voice coil).

Exploded view

In the exploded view, each assembly corresponds to a D/R procedure and the necessary repair kit(s).

i Spare screws and fasteners

Assemblies indicated by a \diamond : order G03615 (KR external screws LA2Xi) for spares.

External modules

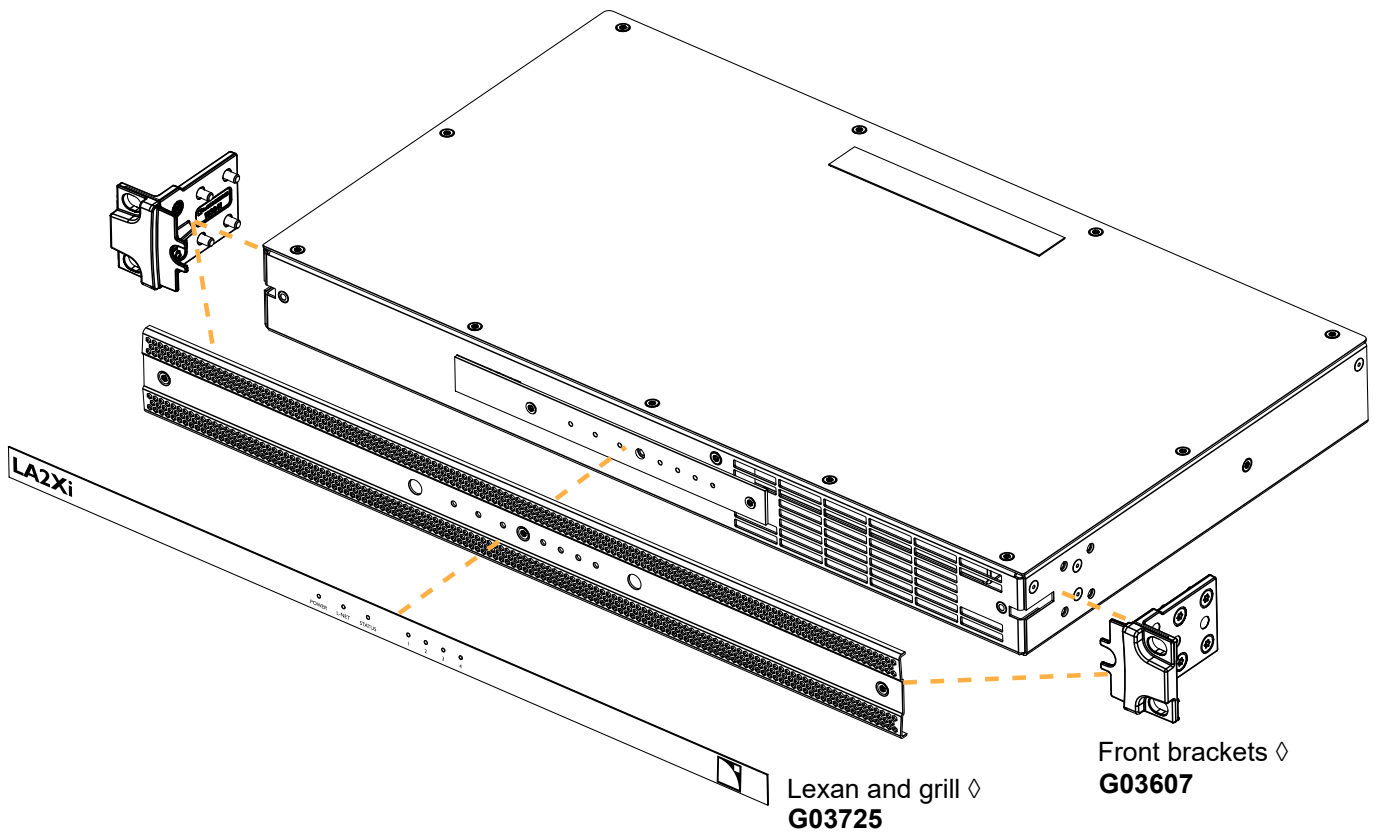

Disassembly and Reassembly procedures

D/R - Lexan and grill

Tools

- 3 mm slotted screwdriver
- torque screwdriver
- smoothing tool (rubber roller)
- T10 Torx bit

Repair kits

G03725

KR grill LA2Xi

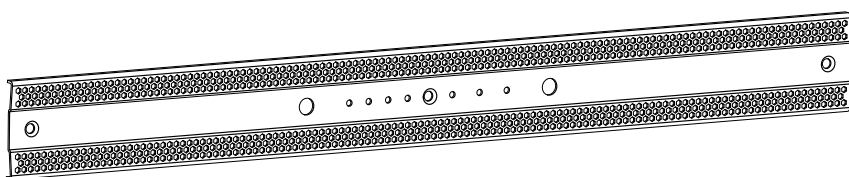

x1

102413

LA2Xi front grill

G03615

KR external screws LA2Xi



x5

S100236

M3x10 Torx

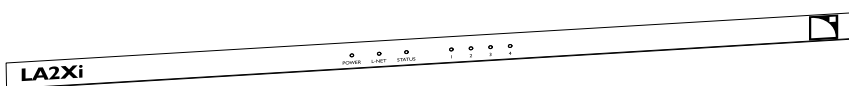

x1

102435

LA2Xi Lexan front panel



LA2Xi Lexan front panel is also available in G03607 - KR brackets & lexan LA2Xi.



Avoid touching the exposed LED board.

ESD (electrostatic discharge) may occur and result in sporadic or persistent failure of electronic boards or components.

Disassembly

Procedure

1. Peel the Lexan.
Use a slotted screwdriver to lift a corner of the Lexan then pull.
2. Remove the front grill from the amplified controller.

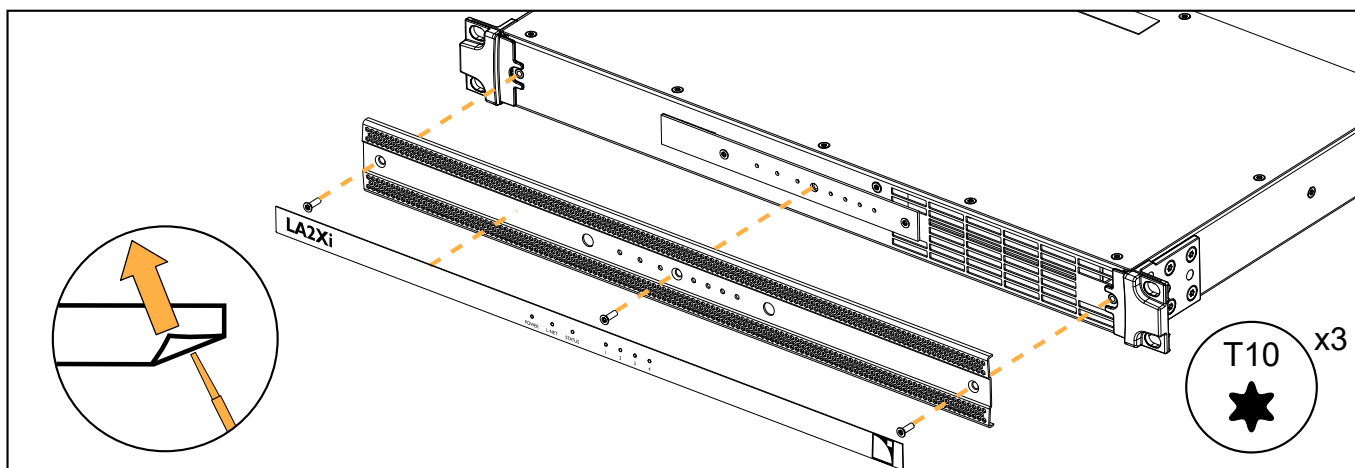

Reassembly

Procedure

1. Secure the grill to the chassis using three M3x10 Torx screws.

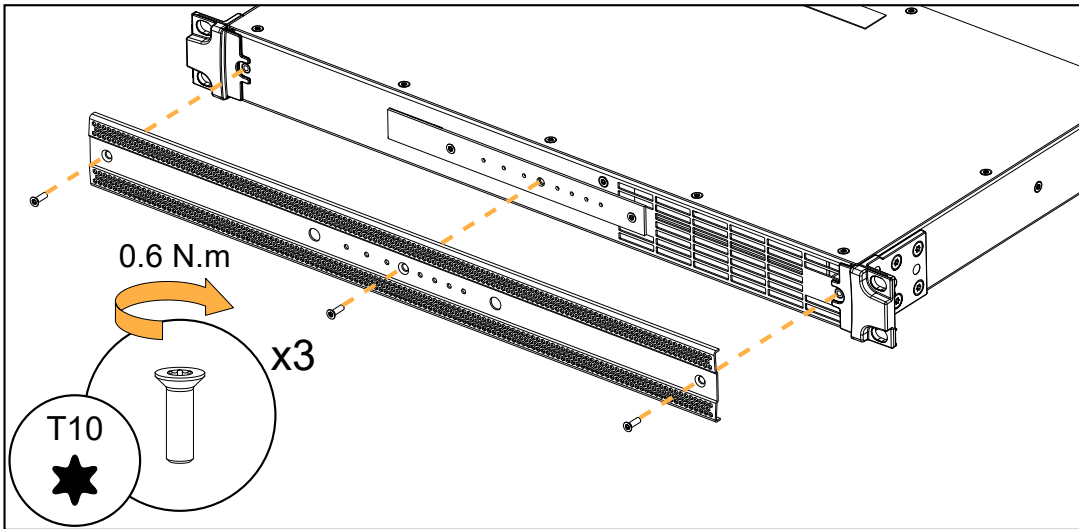

2. Stick the Lexan to the grill:
 - a) Make sure the grill is clean and dust-free.
 - b) Peel the adhesive backing of the Lexan.
 - c) Carefully apply the Lexan to the grill starting from one side.
 - d) Press firmly using a smoothing tool to avoid wrinkles and bubbling.

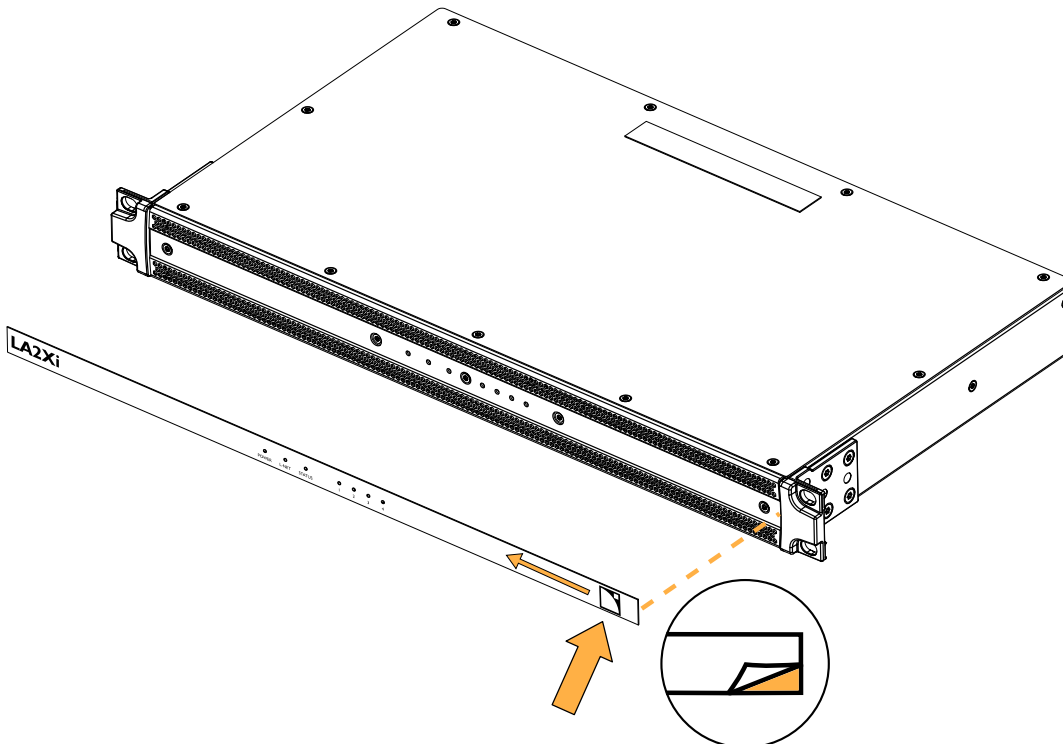

D/R - Front brackets

Tools

- torque screwdriver
- T20 Torx bit

Repair kits

G03607

KR brackets & lexan LA2Xi

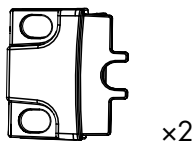

x2

103041

side brackets

G03615

KR external screws LA2Xi



x5

S100085

M4x10 Torx

Prerequisite

Lexan and grill removed.

See [D/R - Lexan and grill](#) (p.45)

Exploded view



Avoid touching the exposed LED board.

ESD (electrostatic discharge) may occur and result in sporadic or persistent failure of electronic boards or components.

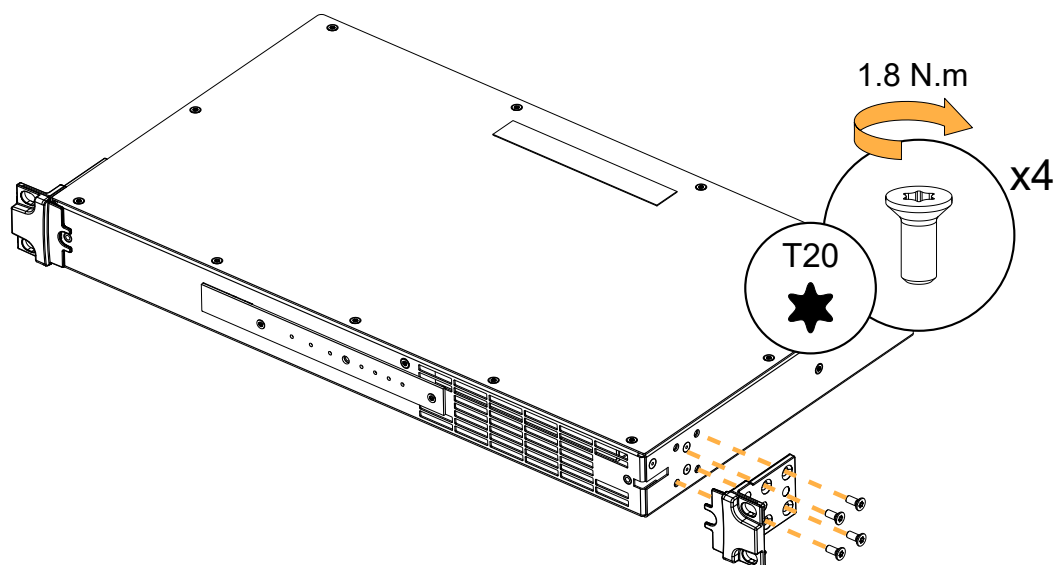

Specifications

All values given in this section are typical values.

General

Output power

12 dB Crest Factor 2 ms, 1 kHz, all channels driven, sine burst	4 × 190 W peak (at 16 Ω) 4 × 370 W peak (at 8 Ω) 4 × 710 W peak (at 4 Ω)
no limiter 200 ms, < 1% THD, 1 kHz, all channels driven, sine burst	4 × 190 W (at 16 Ω) 4 × 360 W (at 8 Ω) 4 × 640 W (at 4 Ω)
Amplification class	High-efficiency Class D
Digital Signal Processor (DSP)	Gen. 4 dual SHARC 32-bit, floating point, 96 kHz sampling rate
Frequency response 20 Hz - 20 kHz	± 0.25 dB
Distortion THD+N	< 0.1%
Output dynamic range	> 113 dB (20 Hz - 20 kHz, 8 Ω, A-weighted, digital input) > 102 dB (20 Hz - 20 kHz, 8 Ω, A-weighted, analog input)
Amplification gain	32 dB
Noise level	< -77 dBV (20 Hz - 20 kHz, 8 Ω, A-weighted, digital input) < -67 dBV (20 Hz - 20 kHz, 8 Ω, A-weighted, analog input)
Channel separation	> 80 dB (at 1 kHz, 8 Ω, 60 W)
Damping factor	> 80 (20 Hz - 200 Hz, 4 Ω load)
Output delay	0 ms to 1000 ms

Mains input power and current draw (all channels driven)

In SE mode

Maximum output power	4 × 190 W at 16 Ω	4 × 360 W at 8 Ω	4 × 640 W at 4 Ω
1/3 output power (-5 dB)	1.9 A / 330 W	2.9 A / 590 W	4.7 A / 1020 W
1/8 output power (-9 dB)	1.2 A / 160 W	1.6 A / 260 W	2.3 A / 440 W

In BTL mode

Maximum output power	2 × 710 W at 16 Ω	2 × 1260 W at 8 Ω
1/3 output power (-5 dB)	2.9 A / 590 W	4.7 A / 1020 W
1/8 output power (-9 dB)	1.6 A / 260 W	2.3 A / 440 W

In PBTL mode

Maximum output power	1 × 780 W at 16 Ω	1 × 1400 W at 8 Ω	1 × 2550 W at 4 Ω
1/3 output power (-5 dB)	1.9 A / 330 W	2.9 A / 590 W	4.7 A / 1020 W
1/8 output power (-9 dB)	1.2 A / 160 W	1.6 A / 260 W	2.3 A / 440 W

Current values given for mains rated at 230 V. Multiply by:

- 2.3 for 100 V
- 1.92 for 120 V
- 1.15 for 200 V

Mains input power and current draw in Idle and Standby modes

Idle	0.5 A / 27 W
Standby	0.4 A / 16 W

Due to line filter operation, power factor is < 0.3 in Idle mode, and < 0.2 in Standby mode. Current values above are given for mains rated at 230 V and decrease with lower mains.

Power supply

Model	universal Switched Mode Power Supply (SMPS) with power factor correction (PFC)
Power factor	> 0.9 (at full load)
Mains rating	100 V AC - 240 V AC ± 10%, 50 Hz - 60 Hz, 550 W
Nominal current requirements	20 A for 100 V AC 15 A for 120 V AC 10 A for 220-240 V AC
Circuit breaker	Use these references, or equipment with equivalent characteristics: 100 V (Japan): 20 A Terasaki S125-NF 1P 120 V (North America): 15 A Square D QO 220-240 V (EU): 10 A Type C
Connector	IEC V-Lock compatible

Operating conditions

Temperature	-5 °C / 23 °F to 50 °C / 122 °F
Maximum altitude	2000 m

Protection

Mains and power supply	over and under voltage over temperature overcurrent (fuse protection, and inrush current protection)
Power outputs	overcurrent DC short circuit over temperature
Transducers protection	L-DRIVE excursion temperature over-voltage
Cooling system	fans with temperature-controlled speed
Fan noise (free field, 1 m)	at minimum speed: 31 dBA at maximum speed: 56 dBA

Interface and connections

Indicators	1 power LED, 1 status LED, and 1 L-NET LED 4 signal LEDs
Output connectors	2 female 4-point terminal blocks
L-NET connectors	2 × 1 Gb/s Ethernet etherCON® I/O
Mini USB connector	1 - for configuring IP settings using the USB Terminal tool of LA Network Manager

Input signal distribution

Interface and connections

Routing and summation matrix	4 × 4
Input	4 male 3-point terminal blocks: 2 for Analog 2 for AES/EBU or Analog
Link	2 male 3-point terminal blocks for AES/EBU or Analog ¹

Analog input

Input impedance	22 kΩ (balanced)
Maximum input level	22 dBu (balanced, THD 1%)
A/D conversion	32-bit analog/digital converter (121 dB dynamic range, A-weighted, 20 Hz - 20 kHz)

¹ The link port can only operate in AES/EBU mode for serial numbers below 1730003000. From 1730003000 and on, the link port can operate in AES/EBU mode and ANALOG mode. On previous units, the link ports are always in AES mode. ANA A and ANA C must be linked like ANA B and ANA D.

Digital input

Supported digital input format

Standards	AES/EBU (AES3)
Sampling frequency (Fs)	44.1, 48, 88.2, 96, 176.4, or 192 kHz
Word length	16, 18, 20, or 24 bits
Synchronization	signal resampled to internal clock at 96 kHz

Sample Rate Converter (SRC)

Sampling frequency	96 kHz (SRC referenced to the amplified controller internal clock)
Word length	24 bits
Dynamic range	140 dB
Distortion THD+N	< -120 dBFS (dB Full Scale)
Bandpass ripple	±0.05 dB 20 Hz - 40 kHz, 96 kHz

Input gain

Range	-12 dB to +12 dB
Steps	0.1 dB

Latency

Analog and AES/EBU

In standard operating mode	3.84 ms
In low latency operating mode	0.84 ms

Milan-AVB

Featured AVB entities	MILAN™-certified, Avnu™-certified Milan-AVB Bridge and Listener
Standards	Ethernet Milan-AVB: IEEE 802.1BA-2011 Transport: IEEE 1722-2016 (AVTP) Control: IEEE 1722.1-2013 (AVDECC)
Input audio stream	Number: 1 in redundancy mode or in normal mode Class: A Maximum network latency: 2 ms Formats: AAF PCM32, up to 2 × 8 channels, at 48 kHz or 96 kHz IEC 61883-6 AM824, 8 channels, at 48 kHz or 96 kHz
Media clock	automatically synchronized on clock of the connected AVB input stream (upsampling at 96 kHz in case of stream at 48 kHz)
Streams forwarded by AVB Bridge (in normal mode)	up to 150

Automatic fallback option

Mode	AVB to AES or analog AES to analog
Switchover conditions	AVB: loss of lock AES to analog: no clock, loss of lock, CRC error, bipolar encoding error or data slip
Constant delay	independent from input Fs
Constant level	upon manual user selection of gain, independent from input Fs
Revert to initial input	upon manual user selection

Remote control and monitoring

Network connection	dual-port Ethernet Gigabit interface
Network redundancy	RSTP
General Purpose I/O (GPIO)	1 × 10-point terminal block: 4 in or out 4 ground 1 × 12 V out 1 for PBTL configuration
External DSP backup voltage input	1 × 24 V DC / 0.5 A 2-point terminal block
L-Acoustics remote control software	LA Network Manager 3
Third-party management solutions	SNMP, Extron [®] , Crestron [®] , QSC Q-SYS

Extron is a registered trademark of Extron Electronics.

Crestron is a trademark or registered trademark of Crestron Electronics, Inc. in the United States, other countries or both.

QSC[®] and Q-SYS[™] are trademarks or registered trademarks of QSC, LLC in the U.S. Patent and Trademark Office and other countries.

Physical data

Height	1U
Weight	4.4 kg / 9.7 lb
Finish	black
Protection rating	IP2x

LA2Xi dimensions

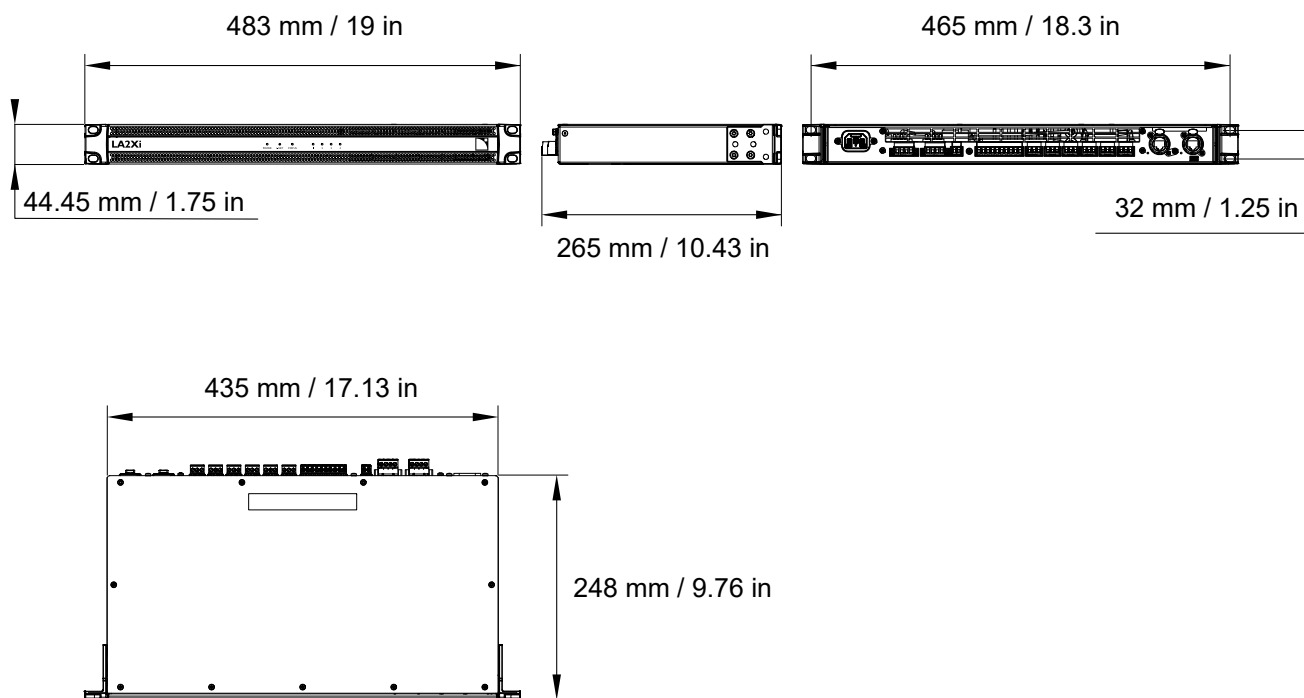

Optional LA2Xi I/O-CON accessory



LA2Xi I/O-CON is an optional XLR and speakON connector panel for LA2Xi.

The rugged panel provides standardized locking connectors for analog and AES/EBU input signals and loudspeaker outputs.

LA2Xi I/O-CON is mounted onto the LA2Xi back panel¹ and covers the original terminal blocks. It offers an alternative connectivity solution based on fast-locking Neutrik connectors widely used in professional audio applications. The ventilated panel offers four XLR female connectors for AES/EBU and analog inputs, two XLR male connectors for AES/EBU and analog⁵ link and two 4-point speakON female connectors for loudspeaker outputs.

The three output modes of LA2Xi, single-ended (SE), bridge-tied load (BTL), and parallel bridge-tied load (PBTl) continue to be available with the LA2Xi I/O-CON. Additionally, two optional L-Acoustics SP cable adapters extend its functionality: the SP-Y1 splits channels to connect passive speakers in SE mode, while the SP5 BTL directly connects subwoofers or passive speakers in BTL mode. A recessed switch allows activation of the PBTl output mode and requires an appropriate custom cable adapter.

The etherCON connectors and the IEC mains connector remain accessible from the LA2Xi chassis.



¹ LA2Xi I/O-CON is compatible with LA2Xi with serial number above 1730002000.

⁵ The link port can only operate in AES/EBU mode for serial numbers below 1730003000. From 1730003000 and on, the link port can operate in AES/EBU mode and ANALOG mode.

LA2Xi I/O-CON panel

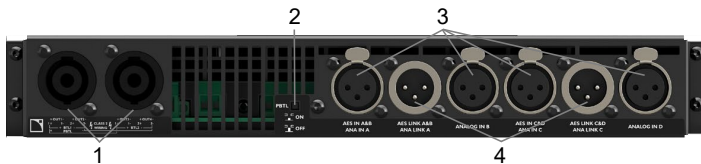

1. female 4-point speakON connectors
2. push-button for selection of the parallel bridge-tied load mode (PBT)
3. female XLR analog and AES/EBU input connectors
4. male XLR analog¹ and AES/EBU link connectors

! GPIO connectors cannot be accessed when LA2Xi I/O-CON is installed on LA2Xi.
The 24 V DC input connector cannot be accessed when LA2Xi I/O-CON is installed on LA2Xi.

Mounting LA2Xi I/O-CON on LA2Xi



Tools

- torque screwdriver
- T10 Torx bit

LA2Xi I/O-CON

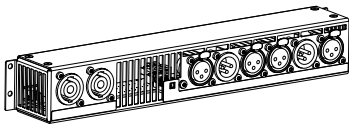

LA2Xi XLR and speakON connector panel



x5

S100177

M3x6 Torx

Chassis from units with serial number above 1730002000 are compatible with LA2Xi I/O-CON.

¹ The link port can only operate in AES/EBU mode for serial numbers below 1730003000. From 1730003000 and on, the link port can operate in AES/EBU mode and ANALOG mode.

Exploded view

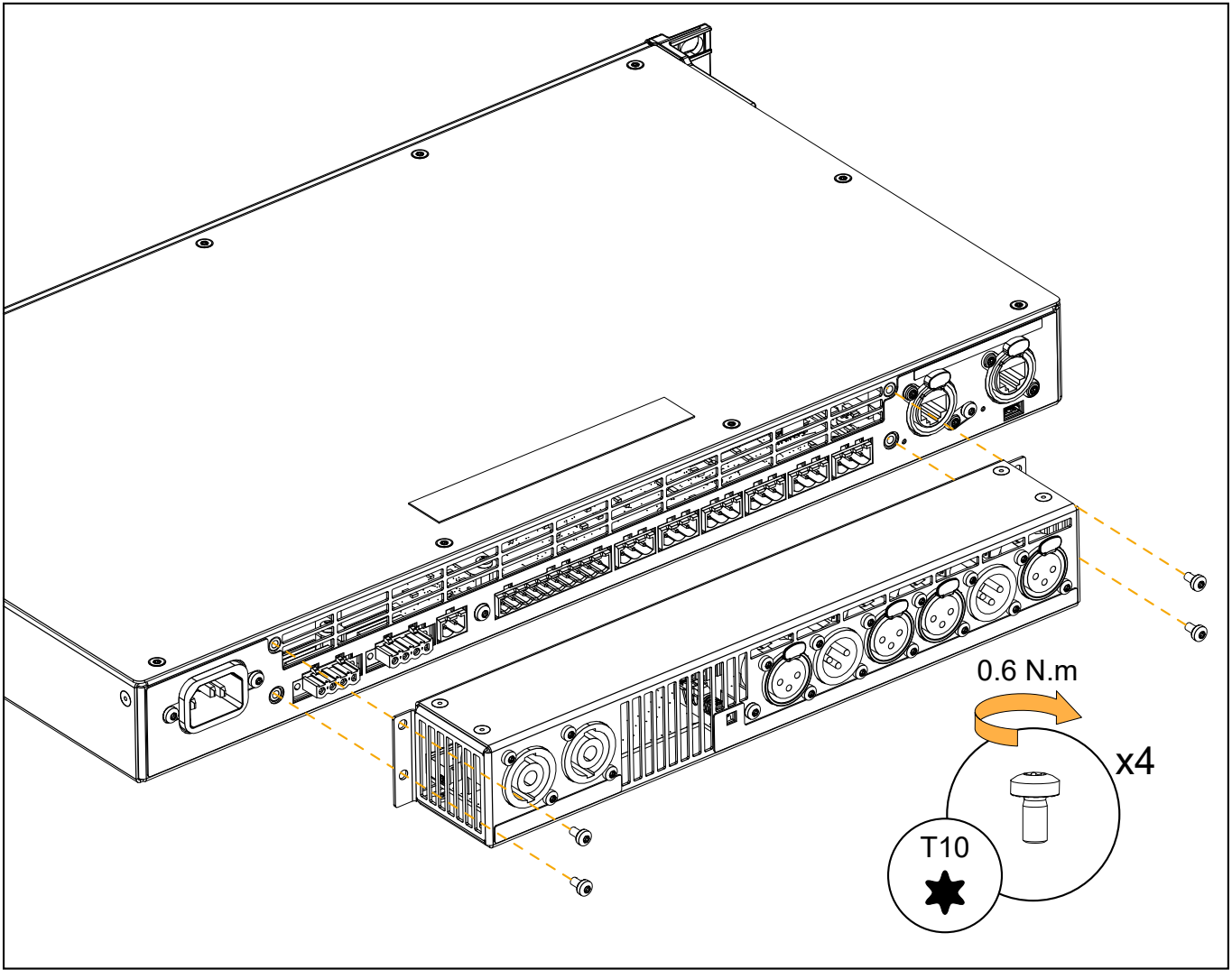

Connection panels

Speaker connectors

Use the two female 4-point speakON connectors for loudspeaker connection.

Two optional L-Acoustics SP cable adapters and one custom cable adapter are used to connect a loudspeaker to the LA2Xi I/O-CON in a single-ended (SE), bridge-tied load (BTL), or a parallel bridge-tied load (PBTL) configuration¹.

SP-Y1

SP-Y1 is a 4-point speakON to 2 × 2-point speakON, provided with a CC4FP adapter. SP-Y1 splits channels to connect passive speakers in SE mode.

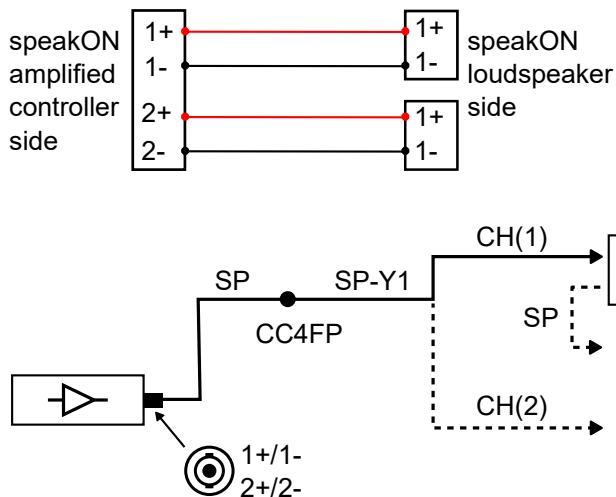

SP5 BTL

SP5 BTL is a 5 m 4-point speakON to 4-point speakON bridged sub cable. SP5 BTL directly connects subwoofers or passive speakers in BTL mode.

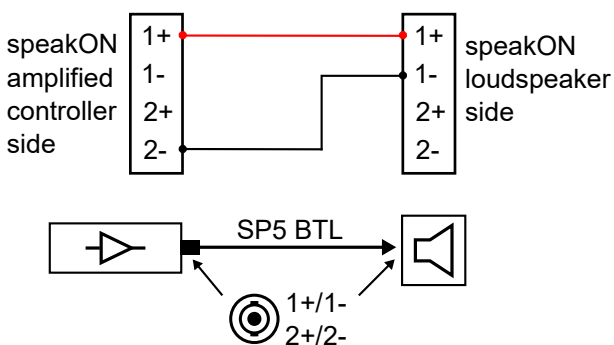

Custom cable adapter

A custom cable adapter and the switch activation of the PBTL mode on LA2Xi I/O-CON are necessary to connect the speakers in PBTL mode. For more information, refer to [Speaker](#) (p.59).

¹ Refer to [Speaker](#) (p.59).

Analog/Digital output connectors

Use the six XLR connectors for analog and digital signal (AES/EBU) cabling.

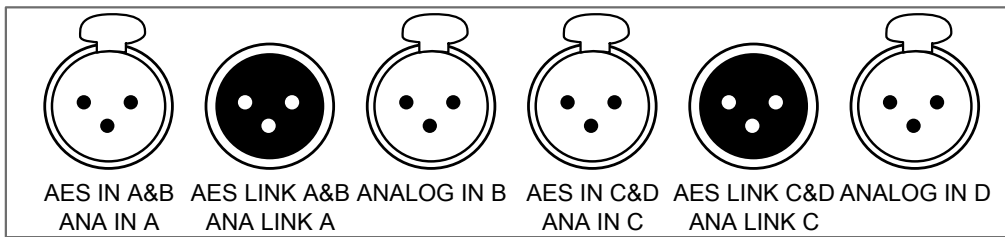

The XLR connectors are wired as follows:

- pin 1: shield
- pin 2: + signal
- pin 3: - signal

For characteristics of the analog and digital (AES/EBU) audio sources and signals, refer to [Analog inputs](#) (p.27), [Analog audio](#) (p.28), and [Digital audio](#) (p.29).

Speaker

About this task

Use the two female 4-point speakON connectors to connect an enclosure to the amplified controller in a single-ended (SE), bridge-tied load (BTL), or a parallel bridge-tied load (PBTL) configuration.

Using the bridge operating modes improves maximum SPL on large loudspeakers, but reduces the maximum number of loudspeaker enclosure per output and per amplified controller. For the enclosure drive capacity per amplified controller, refer to the **Amplification reference** technical bulletin or the **Preset guide**. For the maximum SPL, refer to [Maximum SPL](#) (p.15).

i Using multicore loudspeaker cables

Never connect more than one amplified controller on a single multicore loudspeaker cable.

Connecting several amplified controllers may cause audible interferences on the loudspeaker enclosures when the amplified controllers are in idle mode, even when muted.

Procedure

1. Choose the required operating mode between SE, BTL or PBTL mode.

When used for the first time, the default mode is SE mode.

- PBTL mode: push the **PBTL** button to turn on PBTL mode.
- BTL mode: push again the **PBTL** button to turn on BTL mode (PBTL mode is turned off).

2. Connect the enclosure(s):



Strictly follow the loudspeaker wiring diagrams.

Risk of unwanted noise and errors (bridge modes not operational).

Risk of acoustic cancellations and lack of audio source localization (discrepancy in loudspeaker polarities).

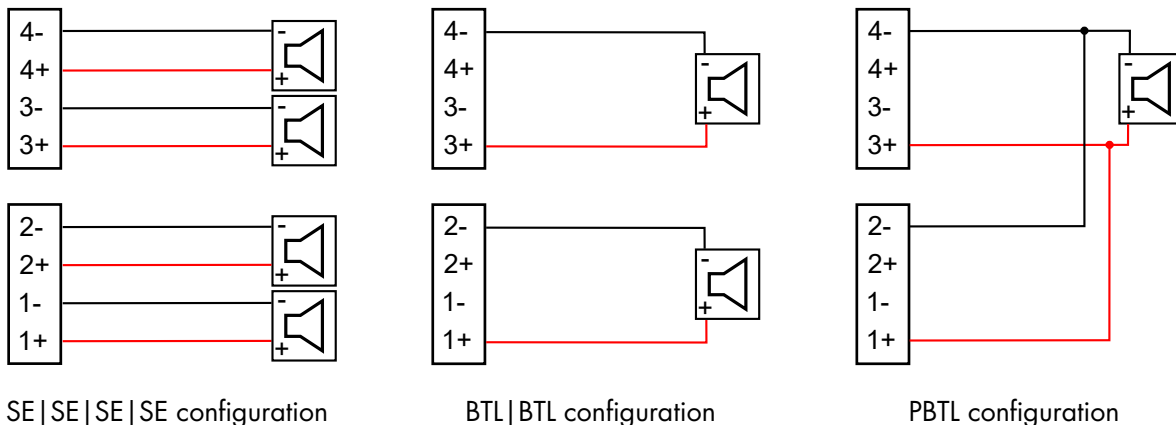

3. Turn on LA2Xi.

If already turned on, either reboot, standby / wake up, or unplug/replug the power cord to apply the changes.

4. Connect LA2Xi to LA Network Manager:

- a) If using an existing session, solve any Unit Type conflicts in the Unit Matcher.
- b) If starting a new session, select the appropriate mode for each unit in the Operating Mode Selector.

Specifications

LA2Xi I/O-CON specifications

Description	LA2Xi XLR and speakON connector panel	
Rear connectors	Outputs	2 × 4-point speakON
	Inputs	4 female XLR
	Links	2 male XLR
Interface	1 push-button for selection of bridge mode (BTL or PBTl)	
Height	1U	
Weight	0.6 kg / 1.2 lb	
Finish	black	

Dimensions

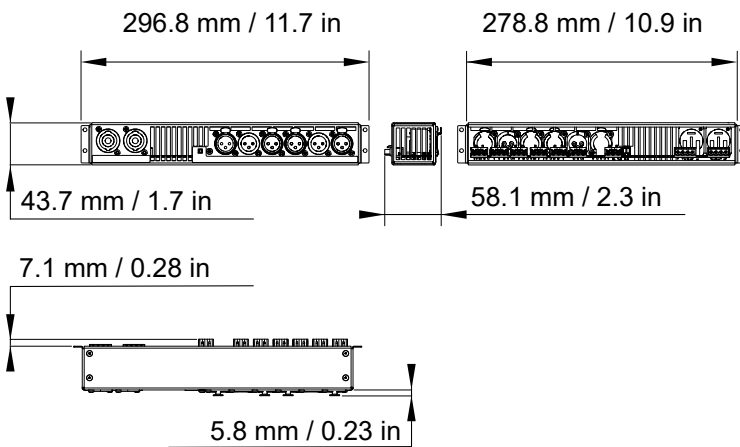

Mounted on LA2Xi

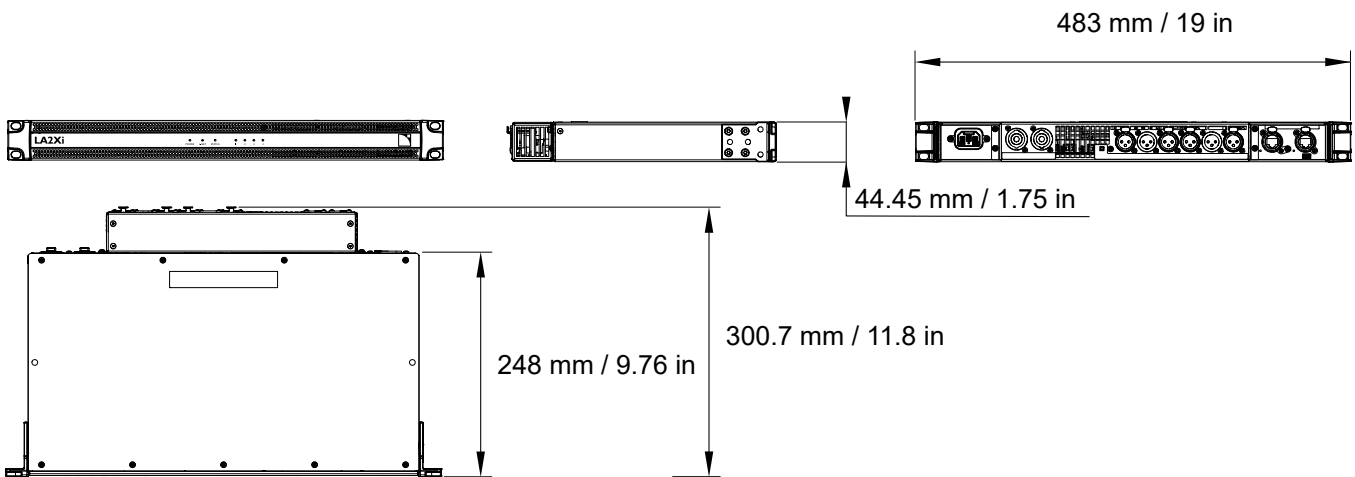

Glossary

CE	Europe
CHK	check procedure
CN	China
D/R	disassembly/reassembly procedure
JP	Japan
KR	repair kit
N.m	newton meter, international torque unit, 1 N.m = 9 in lbf
SMPS	Switched Mode Power Supply (power supply inside of the amplified controller)
US	United States

Approvals

EU Declaration of Conformity (DoC)

EU Declaration of Conformity (DoC)

We

L-Acoustics
13 rue Levacher Cintrat
Parc de la Fontaine de Jouvence
91460 Marcoussis Cedex
France
+33 (0)1 69 63 69 63
info@l-acoustics.com

declare that the DoC is issued under our sole responsibility and belongs to the following product:

LA2Xi amplified controller

The object of the declaration described above is in conformity with the relevant Union harmonization legislation:

2014/35/EU: Low Voltage Directive
2014/30/EU: Electro-Magnetic Compatibility Directive
2011/65/EU: RoHS 2 Directive

The following harmonized standards and technical specifications have been applied:

EN 62368-1: 2014 Audio/video, information and communication technology equipment — Part 1: Safety requirements
EN 55032: 2015 Electromagnetic compatibility of multimedia equipment — Emission Requirements
EN 55035:2017 Electromagnetic compatibility of multimedia equipment — Immunity requirements

Technical file compiled by:

Genio KRONAUER
13 rue Levacher Cintrat
Parc de la Fontaine de Jouvence
91460 Marcoussis Cedex
France

Year CE marking was first affixed: 2020

Issued in Marcoussis, France

13/10/2020



Genio KRONAUER, Electronics Director

LA2Xi is compliant with the following:



Avnu Alliance and the Avnu design mark are registered trademarks and/or service marks of Avnu Alliance.



L-Acoustics

13 rue Levacher Cintrat - 91460 Marcoussis - France
+33 1 69 63 69 63 - info@l-acoustics.com
www.l-acoustics.com

 **L-ACOUSTICS**
GROUP